



Quality Assurance  
Certificate Reg. No:  
04 100 950420



Subject to change without notice  
Manufacturing point: Jeddah, Saudi Arabia  
Nearest port of embarkation: Jeddah Islamic port  
Product classification: Commercial

Product Data Catalog

## 50TJM

Nominal Cooling Capacity 15 - 28 Tons  
HFC R-410A Refrigerant

The 50TJM units are single side discharge rooftop cooling unit utilizing electric heat as an option. Units are pre-wired, pre-charged with R-410A refrigerant, and tested at the factory. These units can be placed on the side of a building or can be placed on a roof without roof curbs. Each unit is designed to occupy a minimal space. Piping and drain connections are readily accessible.

Contact your local Carrier representative for additional reference materials.

# Table of Contents

Features / Benefits.....	2
Shipping Information / Options / Accessories.....	4
Model No. Nomenclature.....	5
AHRI Capacity Ratings.....	6
Physical Data.....	7
Unit Dimensional Drawing.....	9
Cooling Capacities.....	11
Fan Performance Table.....	15
Motor Efficiency / Fan RPM at Motor Pulley Settings / Sound Rating Data.....	19
Electrical Data.....	20
Electric Heater Data.....	21
Wiring Schematic.....	22
Controls.....	24
Guide Specifications.....	25

## Features / Benefits

Every compact one-piece unit arrives fully assembled, charged, tested, and ready to run.

### Durable-Dependable Construction

Designed for durability in any climate, the weather-resistant cabinets are constructed of galvanized steel, bonderized, and all exterior panels are coated with a pre-painted baked enamel finish. The paint finish is non-chalking, and is capable of withstanding ASTM (American Society for Testing and Materials) B117 500-hour Salt Spray Test. All internal cabinet panels are primed, permitting longer life and a more attractive appearance for the entire unit. Totally enclosed condenser-fan motor and permanently lubricated bearings provide additional unit dependability.

### Indoor-Air Quality

Non corrosive sloped condensate pans minimize biological growth in rooftop units in accordance with ASHRAE (American Society of Heating, Refrigeration and Air Conditioning Engineers) Standard 62-99 (IAQ). 1"inch filters provide for greater particle reduction in the return air.

### Simple, Electrical Connections

Terminal boards, located in the unit control box, facilitate connections to room thermostat, outdoor thermostat(s) and electric heater. Service panels are quickly removed, permitting easy servicing. Both power and control connections are made on the same side of the unit to simplify installation. In addition, color-coded wires permit easy tracing and diagnostics.

### Easy Installation

All units feature base rail design with forklift slots and rigging holes for easier maneuvering. Durable packaging protects all units during shipment and storage. Convenient side by side openings permit installation very close to face of buildings or on roof top. The non-corrosive sloped condensate pan minimizes residual condensate in off cycle. An external, field-supplied P-trap is required. Field-installed electric heaters are available in two convenient capacities 30kW or 40kW.

## **Installation Features**

- Single point electrical service entry
- Side discharge application
- No roof curb needed
- Side by side supply and return air
- Separate panel for control box

## **Performance Features**

- HFC R-410A refrigerant
- ASHRAE Compliant
- EER's up to 11
- TXV refrigerant metering device
- Two independent refrigerant circuits, each with a scroll compressor
- Low outdoor temperature cooling operation down to 40° F
- Liquid filter drier standard on each circuit
- 10% fresh air intake
- Non-corrosive sloped condensate drain pan in accordance to ASHRAE 62 standard
- Thermally protected and permanently lubricated condenser and evaporator fan motors
- Angle type return air section with washable type filters

## **Environmentally Sound Refrigerant Choice**

R410A refrigerant is:

- A chlorine-free refrigerant from the HFC group
- Has zero ozone depletion potential
- High pressure refrigerant, therefore less refrigerant is required
- Thermally efficient and provides high EER (energy efficiency), COP, and part load efficiencies

## **Superior Reliability, Efficiency and Safety**

- Exceptional endurance tests
  - Painted panels tested to ASTM B-117 500 hours salt spray protection
  - Pre-coated fin condenser coil for extra corrosion protection
- Compressor Protection:
  - High and low pressure cutouts
  - Compressor lockout
  - Phase protection relay
  - Crankcase heaters are standard for all units
  - Internal over temperature protection
  - Freeze protection
- Low vibration design:
  - Leak-tight refrigerant circuit
  - Brazed refrigerant connections for increased leak tightness
  - Low-noise scroll compressors with low vibration levels
- Control circuit protected by circuit breaker
- Thermally protected and permanently lubricated condenser and evaporator fan motors
- Angle type return air section with washable type filters
- Transformer for safe 24v control circuit supply included
- High Efficiency, High Static Blower
- State-of-art scroll compressor technology
- Dual, electrically and mechanically independent refrigerant circuit
- Double skin construction, Insulated cabinet

## SHIPPING INFORMATION

### Unit data with Condenser Al/Cu and Evaporator Cu/Al Coils and Condenser only Pre-coat Al/CU

Unit Model	Cap.	Approximate Shipping Weight		Approximate Shipping Dimensions (L x D x H)	
Number	Tons	kg	lbs	mm	in
50TJM-18AxAxxxAxAS	15	925	2,017	2,440x2,235x1,375	96x88x54
50TJM-24AxAxxxAxAS	19	945	2,050		
50TJM-28AxAxxxAxAS	23	1,190	2,854	3,200x2,485x1,400	126x98x55
50TJM-34AxAxxxAxAS	28	1,215	2,877		

### Unit data with Condenser Only Cu/Cu Coils

Unit Model	Cap.	Approximate Shipping Weight		Approximate Shipping Dimensions (L x D x H)	
Number	Tons	kg	lbs	mm	in
50TJM-18AxExxxAxAS	15	990	2,183	2,440x2,235x1,375	96x88x54
50TJM-24AxExxxAxAS	19	1,032	2,275		
50TJM-28AxExxxAxAS	23	1,340	2,954	3,200x2,485x1,400	126x98x55
50TJM-34AxExxxAxAS	28	1,365	3,009		

### Unit data with Condenser and Evaporator Cu/Cu Coils

Unit Model	Cap.	Approximate Shipping Weight		Approximate Shipping Dimensions (L x D x H)	
Number	Tons	kg	lbs	mm	in
50TJM-18AxCxxxAxAS	15	1,074	2,367	2,440x2,235x1,375	96x88x54
50TJM-24AxCxxxAxAS	19	1,116	2,460		
50TJM-28AxCxxxAxAS	23	1,452	3,201	3,200x2,485x1,400	126x98x55
50TJM-34AxCxxxAxAS	28	1,477	3,256		

## FACTORY INSTALLED OPTIONS

Option	Description
Indoor fan system	Standard
	High efficiency motor
Refrigerant sight glass	Installed on each circuit
Pre-coated	Condenser only
Copper fins	Condenser only
Copper fins	Evaporator and Condenser

NOTE: Please refer to the Product Nomenclature for ordering information

## FIELD INSTALLED ACCESSORIES

### Accessory Electric Heater - 400V

UNIT 50TJM	Complete Kit P.N.	Casing P.N.	Heater Element P. N.	Electric Heater Kits		
		( 1 Per Kit )	( 2 Per Kit )	Description	Stages	Size (Kw)
18	50TJ600287	50TJ600289	CPHEATER036A00	Duct heater assembly, 480V	2	30
24	50TJ601162	50TJ600289	CPHEATER037A00	Duct heater assembly, 480V	2	40
28	50TJ600730	50TJ600727	CPHEATER037A00	Duct heater assembly, 480V	2	40
34	50TJ600730	50TJ600727	CPHEATER037A00	Duct heater assembly, 480V	2	40

NOTE: Heaters are rated at 480 V. Use the Multiplication Factors table below to determine heater capacity for your particular voltage.

Heater Rating Voltage	Multiplication Factors			
	380	400	460	480
480	0.620	0.700	0.920	1.000

# MODEL NUMBER NOMENCLATURE – 50TJM – R410A SERIES

1	2	3	4	5	6	7	8	9	10	11	12	13	14	15	16	17	18
5	0	T	J	M	-	1	8	A	9	A	1	A	0	A	0	A	S

**Source**  
S = SAMCO

**Unit Heat Type**  
50 = Cooling / Electric Heat RTU

**Electrical Options**  
A = None

**Model Series**  
TJM = High Ambient Desert Master Series with R-410A Refrigerant

**Service Options**  
0 = None  
1 = Sight Glass

**Factory Use**

**IAQ Options**  
A = None

**Nominal Cooling Capacity**  
18 = 15 Ton  
24 = 19 Ton  
28 = 23 Ton  
34 = 28 Ton

**Base Unit Controls**  
0 = Electromechanical Controller

**Design Review**  
A = Factory Assigned

**Sensor Options**  
A = None

**Indoor Fan Motor Options**  
1 = Standard  
2 = High Efficiency

**Power Supply (V/Ph/Hz)**  
2 = 400/3/60  
5 = 230/3/60  
6 = 460/3/60  
9 = 400/3/50

**Coil Fins Options (Outdoor - Indoor)**  
A = Al/Cu - Al/Cu  
B = Pre-coat Al/Cu - Al/Cu  
C = Cu/Cu - Cu/Cu  
E = Cu/Cu - Al/Cu

## AHRI Capacity Rating\*

Unit 50TJM	Nominal Ton	Standard CFM	Net Cooling Capacity (BTU/hr)	Net Cooling Capacity (Watt)	Net Cooling Capacity (Ton)	CFM/TON	EER	Sound Rating (Decibels)
18	15	5,300	172724	50637	14.4	368	11.2	90.3
24	19	6,700	208745	61197	17.4	385	11.1	90.9
28	23	8,000	259367	76038	21.6	370	11.7	90.6
34	28	9,000	302972	88821	25.2	356	10.5	91.1

Bels - Sound Levels (1 bel = 10 decibels)

EER - Energy Efficiency Ratio

\*AHRI - Air Conditioning, Heating and Refrigeration Institute.

1. Rated in accordance with AHRI Standards 210/240-89 or 360-86 and 270-84.
2. Ratings are net values, reflecting the effects of circulating fan heat.

Cooling Standard: 80 F db, 67 wb indoor entering-air temperature and 95 F db air entering outdoor unit, Side Discharge, 0.4 iwg External Static. .

# Physical Data - English

## 50TJM Unit Physical Data (50Hz) (English)

Unit 50TJM Size	18	24	28	34
Unit Dimensions	Page - 9		Page - 10	
Unit Operating Weight	Page - 9		Page - 10	

### Refrigeration System

Compressor No. / Type	2 / Scroll			
Stage Of Capacity Control (%)	50 / 50			
Refrigerant Type	Puron ® R410A			
Circuits No.	2			
Charge Per Circuit (1 - Down / 2 - Up) -LBS.OZ	15 - 9 / 15 - 9	22 - 3 / 25 - 10	31 - 3 / 29 - 3	31 - 10 / 31 - 6
Metering Device	TXV - Adjustable			
Filter Drier Qty / Size	2 / DML085S		2 / DMS165S	
High Pressure Switch (Trip / Reset) - PSIG	630 / 480			
Low Pressure Switch (Trip / Reset) - PSIG	54 / 70			
Freeze Protection Thermostat (Open / Close) ±1.8 °F	-18 / -14			

### Condenser Coil

Coil Type	Copper Tube, Aluminum Double Wavy Fins			Copper Tube, Aluminum LSW Fins
Standard Coil Material	Copper / Aluminium			
Qty x Rows x FPI	1 x 3 x 16	1 x 4 x 16	2 x 3 x 17	
Qty x Face Area (ft <sup>2</sup> )	1 x 26.7		2 x 28.8	
Coil Test Pressure (PSIG)	450			

### Condenser Fan & Motor

Approx. Air Flow Rate (CFM)	12000	13000	18200	16700
Quantity	2			
Diameter (in) / No. of Blades	30 / 4		30 / 6	
Motor Type	Induction Motor - Totally Enclosed			
Motor HP / RPM	1 / 950			

### Evaporator Coil

Coil Type	Copper Tube, Aluminum LSW Fins.			
Standard Coil Material	Copper / Aluminium			
Qty x Rows Qty x FPI	2 x 3 x 17		2 x 4 x 17	
Qty x Face Area (ft <sup>2</sup> )	2 x 9.75		2 x 10.3	
Coil Test Pressure	350			
Drain Pan connection Size (in)	3/4			
Return Air Filter Qty x Size (in)	4 x 33.8 x 21.7		4 x 35.4 x 21.7	

### Evaporator Fan and Motor Section

Fan Quantity / Fan Size (in)	1 / 15.75 x 15.75		1 / 17.7 x 17.7	
Fan Type	Centrifugal - Forward Blade			
Drive Type	Belt			
Motor Type	Induction Motor - TEFC			
Motor BHP	4.0	5.5	7.5	
Motor Frame Size / Motor Shaft Diameter (mm)	100 / 28	112 / 28		132 / 38
Motor Pulley Pitch Diameter (Min / Max) (in)	3.7 / 4.7			4.3 / 5.6
Fan RPM Range (RPM)	1030 - 745	1041 - 753		1029 - 740
Fan Pulley Pitch Diameter (in)	6.6			8.4
Belt, Quantity...Type	1 ... BX66			1 ... BX71
Pulley Center To Center Distance(in)	24.4 - 27.51			
Movable Pulley Maximum Full Turns From Closed Position	6			
Approx.Speed Change Per Full Turn Of Movable Pulley Flange (rpm)	48			
Factory Speed Turns Setting	4			1.5
Factory Belt Standard Deflection (in) @ Force (Lb)	0.39 @ 4.65 Lb	0.39 @ 5.99 Lb		0.40 @ 6.63 Lb

# Physical Data - SI

50TJM Unit Physical Data (50Hz) (SI)				
Unit 50TJM Size	18	24	28	34
Unit Dimensions	Page - 9		Page - 10	
Unit Operating Weight	Page - 9		Page - 10	
<b>Refrigeration System</b>				
Compressor No. / Type	2 / Scroll			
Stage Of Capacity Control (%)	50 / 50			
Refrigerant Type	Puron ® R410A			
Circuits No.	2			
Charge Per Circuit (1 - Down / 2 - Up) - kG	7.23 / 7.23	10.12 / 11.4	14.15 / 13.3	14.34 / 14.23
Metering Device	TXV- Adjustable			
Filter Drier Qty / Size	2 / DML085S		2 / DMS165S	
High Pressure Switch (Trip / Reset) - Bar	43 / 33			
Low Pressure Switch (Trip / Reset) - Bar	4 / 5			
Freeze Protection Thermostat (Open / Close) ±1 °C	-1 / 7			
<b>Condenser Coil</b>				
Coil Type	Copper Tube, Aluminium Double Wavy Fins			Copper Tube, Aluminium LSW Fins
Standard Coil Material	Copper / Aluminium			
Qty x Rows x Fins	1 x 3 x 1280	1 x 4 x 1280	2 x 3 x 1472	
Qty x Face Area (m <sup>2</sup> )	1 x 2.5		2 x 2.7	
Coil Test Pressure (PSIG)	31			
<b>Condenser Fan &amp; Motor</b>				
Approx. Air Flow Rate (m <sup>3</sup> /hr)	20376	22074	30903.6	28356.6
Quantity	2			
Diameter (mm) / No. of Blades	762 / 4		762 / 6	
Motor Type	Induction Motor - Totally Enclosed			
Motor HP/ RPS	1 / 16			
<b>Evaporator Coil</b>				
Coil Type	Copper Tube, Aluminium LSW Fins			
Standard Coil Material	Copper / Aluminium			
Qty x Rows x Fins	2 x 3 x 663		2 x 4 x 663	
Qty x Face Area (m <sup>2</sup> )	2 x 0.91		2 x 0.96	
Coil Test Pressure	24			
Drain Pan connection Size (mm)	19.05			
Return Air Filter Qty x Size (in)	4 x 860 x 550		4 x 900 x 550	
<b>Evaporator Fan and Motor Section</b>				
Fan Quantity / Fan Size (mm)	1 / 400 x 400		1 / 450 x 450	
Fan Type	Centrifugal- Forward Blade			
Drive Type	Belt			
Motor Type	Induction Motor - TEFC			
Motor BkW	3.0	4.0	5.5	
Motor Frame Size / Motor Shaft Diameter (mm)	100 / 28	112 / 28		132 / 38
Motor Pulley Pitch Diameter (Min / Max) (mm)	94 / 119.4			109 / 141.6
Fan RPM Range (r/s)	17.2 - 12.4	17.4 - 12.5		17.2 - 12.3
Fan Pulley Pitch Diameter (mm)	167.6			212.2
Belt, Quantity... Type	1 ... BX66		1 ... BX71	
Pulley Center To Center Distance(mm)	620 - 699			
Movable Pullley Maximum Full Turns From Closed Position	6			
Approx. Speed Change Per Full Turn Of Movable Pulley Flange (rps)	0.8			
Factory Speed Turns Setting	4			1.5
Factory Belt Standard Deflection (mm) @ Force (N)	10 @ 20.7 N	10 @ 26.7 N		10.2 @ 29.5 N



**UNIT DIMENSIONAL DRAWING: 50TJM - 18 and 50TJM - 24**

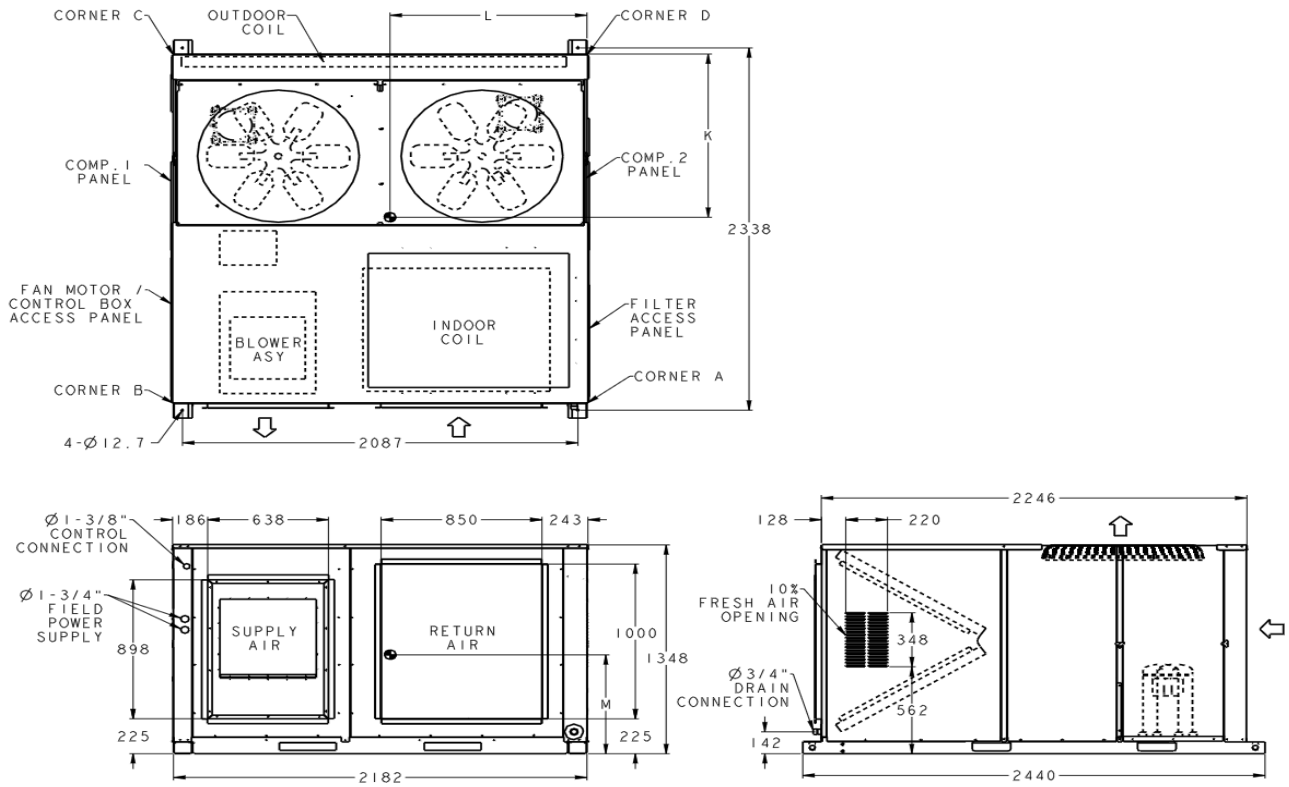

UNIT	SHIPPING DIMENSIONS (mm)			CORNER WEIGHT (Kg)					CENTER OF GRAVITY (mm)		
	LENGTH	WIDTH	DEPTH	A	B	C	D	TOTAL	K	L	M
50TJM - 18	2440	2235	1375	192	178	236	254	860	1050	1050	450
50TJM - 24				197	182	241	260				

**NOTES:**

- Dimensions are in millimeters.
- Center of Gravity.
- Direction of Airflow
- Minimum clearance:
  - REAR: 2134mm for coil removal. This dimension can be reduced to 1219mm if conditions permit coil removal from the top.
  - TOP: 1829mm to assure proper condenser fan operation.
  - SIDE: 1219mm for Compressor, Filter and Control boxes access.
  - Local codes or jurisdiction may prevail.
- With the exception of clearance for the condenser coil and the damper / power exhaust as stated in Note no. 6, a removal fence or barricade requires no clearance.
- Dimensions are from outside of corner post. Allow 8mm on each side for top cover drip edge.
- Weights are Given for aluminum evaporator and condenser coil plate fins.

**UNIT DIMENSIONAL DRAWING: 50TJM - 28 and 50TJM - 34**

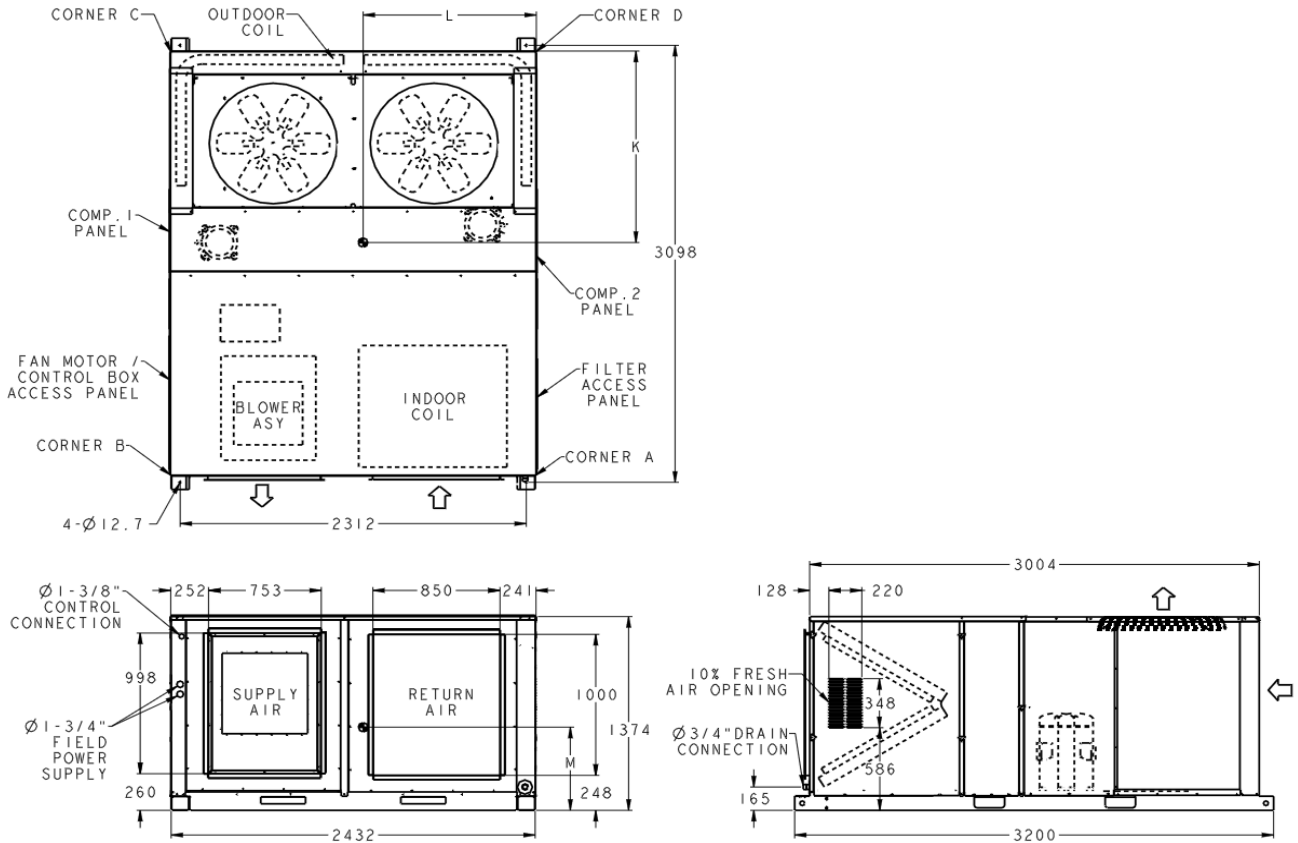

UNIT	SHIPPING DIMENSIONS (mm)			CORNER WEIGHT (Kg)					CENTER OF GRAVITY (mm)		
	LENGTH	WIDTH	DEPTH	A	B	C	D	TOTAL	K	L	M
50TJM - 28	3200	2485	1400	248	226	310	340	1125	1350	1160	450
50TJM - 34				254	231	317	348	1150			

**NOTES:**

- Dimensions are in millimeters.
- Center of Gravity.
- ⇨ Direction of Airflow
- Minimum clearance:
  - REAR: 2134mm for coil removal. This dimension can be reduced to 1219mm if conditions permit coil removal from the top.
  - TOP: 1829mm to assure proper condenser fan operation.
  - SIDE: 1219mm for Compressor, Filter and Control boxes access.
  - Local codes or jurisdiction may prevail.
- With the exception of clearance for the condenser coil and the damper / power exhaust as stated in Note no. 6, a removal fence or barricade requires no clearance.
- Dimensions are from outside of corner post. Allow 8mm on each side for top cover drip edge.
- Weights are Given for aluminum evaporator and condenser coil plate fins.

# Cooling Capacities

50TJM18-50Hz													
Temp (F) Air Entering Condenser (Edb)		Evaporator Air - CFM/BPF											
		4000 / 0.15			5300 / 0.18			6300 / 0.19			7000 / 0.22		
		Evaporator Air - EWB (F)											
		62	67	72	62	67	72	62	67	72	62	67	72
75	TC	164,123	178,180	193,776	175,986	190,178	206,306	185,185	200,292	216,925	195,996	206,122	223,320
	SHC	131,993	114,134	96,352	153,051	130,267	107,023	169,604	148,959	119,152	183,329	160,089	127,457
	kW	8.04	8.16	8.30	8.12	8.25	8.40	8.20	8.32	8.47	8.25	8.34	8.50
85	TC	158,492	172,458	187,247	169,344	183,311	198,529	179,977	191,990	207,940	188,533	197,207	213,847
	SHC	128,991	110,963	92,629	147,800	126,822	102,967	167,231	144,615	114,827	176,040	154,809	123,056
	kW	9.40	9.53	9.67	9.47	9.60	9.76	9.56	9.66	9.82	9.61	9.69	9.85
95	TC	152,533	165,913	179,837	161,987	<b>175,372</b>	189,758	173,764	182,643	198,030	181,098	187,980	203,412
	SHC	123,850	105,923	87,266	139,632	<b>120,656</b>	97,028	158,406	137,112	108,504	165,215	147,844	116,432
	kW	10.87	11.01	11.16	10.95	<b>11.08</b>	11.24	11.05	11.13	11.30	11.10	11.17	11.32
105	TC	143,923	155,825	168,836	152,028	163,833	177,318	163,841	170,218	184,307	170,656	175,396	189,235
	SHC	121,184	102,659	83,727	135,060	116,870	93,265	150,300	133,352	104,519	156,552	143,817	112,301
	kW	12.23	12.35	12.51	12.32	12.42	12.57	12.41	12.47	12.62	12.45	12.50	12.65
115	TC	133,818	144,809	156,813	143,621	151,553	164,004	153,119	157,411	170,013	159,384	161,953	174,742
	SHC	115,117	97,738	78,907	130,927	111,377	88,113	139,585	127,782	98,995	145,297	136,464	106,299
	kW	13.78	13.90	14.05	13.86	13.95	14.10	13.96	14.00	14.15	14.00	14.03	14.16
118.4	TC	126,844	137,259	148,597	136,584	143,339	155,227	145,452	148,857	160,821	151,388	153,172	165,397
	SHC	106,117	90,430	72,675	120,060	102,952	81,274	127,855	118,083	91,329	133,073	125,775	98,068
	kW	13.93	14.04	14.18	14.00	14.09	14.24	14.11	14.14	14.28	14.15	14.17	14.30
125	TC	118,734	127,396	137,807	127,571	132,660	143,641	135,640	137,670	148,932	141,143	141,846	153,246
	SHC	102,134	86,480	68,863	112,507	98,180	77,247	119,623	112,411	86,760	124,476	119,585	93,242
	kW	15.53	15.65	15.79	15.62	15.70	15.83	15.72	15.74	15.87	15.76	15.78	15.89

50TJM18-50Hz													
Temp (C) Air Entering Condenser (Edb)		Evaporator Air - (L/s)/BPF											
		1888 / 0.150			2501 / 0.175			2973 / 0.188			3304 / 0.220		
		Evaporator Air - EWB (C)											
		17	19	22	17	19	22	17	19	22	17	19	22
24	TC	48.1	52.2	56.8	51.6	55.7	60.5	54.3	58.7	63.6	57.4	60.4	65.5
	SHC	38.7	33.5	28.2	44.9	38.2	31.4	49.7	43.7	34.9	53.7	46.9	37.4
	kW	8.04	8.16	8.30	8.12	8.25	8.40	8.20	8.32	8.47	8.25	8.34	8.50
29	TC	46.5	50.5	54.9	49.6	53.7	58.2	52.7	56.3	60.9	55.3	57.8	62.7
	SHC	37.8	32.5	27.1	43.3	37.2	30.2	49.0	42.4	33.7	51.6	45.4	36.1
	kW	9.40	9.53	9.67	9.47	9.60	9.76	9.56	9.66	9.82	9.61	9.69	9.85
35	TC	44.7	48.6	52.7	47.5	<b>51.4</b>	55.6	50.9	53.5	58.0	53.1	55.1	59.6
	SHC	36.3	31.0	25.6	40.9	<b>35.4</b>	28.4	46.4	40.2	31.8	48.4	43.3	34.1
	kW	10.87	11.01	11.16	10.95	<b>11.08</b>	11.24	11.05	11.13	11.30	11.10	11.17	11.32
40.6	TC	42.2	45.7	49.5	44.6	48.0	52.0	48.0	49.9	54.0	50.0	51.4	55.5
	SHC	35.5	30.1	24.5	39.6	34.3	27.3	44.1	39.1	30.6	45.9	42.2	32.9
	kW	12.23	12.35	12.51	12.32	12.42	12.57	12.41	12.47	12.62	12.45	12.50	12.65
46	TC	39.2	42.4	46.0	42.1	44.4	48.1	44.9	46.1	49.8	46.7	47.5	51.2
	SHC	33.7	28.6	23.1	38.4	32.6	25.8	40.9	37.5	29.0	42.6	40.0	31.2
	kW	13.78	13.90	14.05	13.86	13.95	14.10	13.96	14.00	14.15	14.00	14.03	14.16
48	TC	37.2	40.2	43.6	40.0	42.0	45.5	42.6	43.6	47.1	44.4	44.9	48.5
	SHC	31.1	26.5	21.3	35.2	30.2	23.8	37.5	34.6	26.8	39.0	36.9	28.7
	kW	13.93	14.04	14.18	14.00	14.09	14.24	14.11	14.14	14.28	14.15	14.17	14.30
52	TC	34.8	37.3	40.4	37.4	38.9	42.1	39.8	40.3	43.6	41.4	41.6	44.9
	SHC	29.9	25.3	20.2	33.0	28.8	22.6	35.1	32.9	25.4	36.5	35.0	27.3
	kW	15.53	15.65	15.79	15.62	15.70	15.83	15.72	15.74	15.87	15.76	15.78	15.89

**Boldface** - Standard Ratings

## LEGEND

- BF — Bypass Factor
- Edb — Entering Dry-Bulb
- Ewb — Entering Wet-Bulb
- SHC — Sensible Heat Capacity (1000 Btuh) Gross
- Ldb — Leaving Dry-Bulb
- Lwb — Leaving Wet-Bulb
- TC — Total Capacity (1000 Btuh) Gross
- kW — Compressor Motor Power Input

# Cooling Capacities (cont)

50TJM24-50Hz													
Temp (F) Air Entering Condenser (Edb)		Evaporator Air - CFM/BPF											
		5000 / 0.176			5700 / 0.182			6700 / 0.214			7500 / 0.230		
		Evaporator Air - EWB (F)											
		62	67	72	62	67	72	62	67	72	62	67	72
75	TC	196,725	213,978	232,610	204,185	221,923	241,096	211,823	231,485	250,898	221,461	239,050	258,795
	SHC	153,750	132,986	111,976	165,959	142,513	118,607	179,177	156,256	127,652	193,096	167,955	135,897
	kW	10.29	10.44	10.61	10.33	10.50	10.68	10.40	10.58	10.76	10.45	10.62	10.81
85	TC	190,371	206,895	224,836	196,819	214,308	232,608	206,126	223,064	241,680	213,401	230,056	249,041
	SHC	152,443	130,879	109,329	163,548	140,603	115,829	179,063	154,250	124,901	190,517	165,767	133,069
	kW	11.72	11.89	12.08	11.78	11.95	12.14	11.85	12.03	12.22	11.90	12.07	12.26
95	TC	183,049	199,130	216,147	188,040	205,694	223,183	198,657	<b>213,598</b>	231,440	204,758	220,041	238,244
	SHC	150,337	128,815	106,420	159,404	138,276	112,813	174,329	<b>151,655</b>	121,790	184,626	162,933	129,964
	kW	13.30	13.47	13.66	13.35	13.53	13.73	13.45	<b>13.60</b>	13.80	13.49	13.64	13.84
105	TC	172,690	188,247	204,406	179,248	194,067	210,527	187,083	201,018	217,886	194,692	206,774	224,080
	SHC	144,243	123,897	101,506	155,063	133,109	107,607	167,216	145,992	116,412	176,459	156,818	124,411
	kW	14.68	14.87	15.07	14.74	14.92	15.12	14.83	14.99	15.19	14.95	15.02	15.22
115	TC	162,397	177,341	192,558	169,067	182,371	197,884	177,288	188,527	204,408	185,748	193,594	209,995
	SHC	137,711	119,274	96,782	149,040	128,208	102,757	160,040	140,715	111,392	169,265	151,000	119,276
	kW	16.40	16.59	16.79	16.47	16.65	16.84	16.57	16.70	16.90	16.64	16.73	16.93
118.4	TC	149,791	163,255	177,277	156,002	167,799	182,045	164,487	173,334	187,962	171,414	178,021	193,048
	SHC	128,689	111,418	90,119	138,634	119,854	95,734	150,496	131,517	103,900	156,834	141,254	111,329
	kW	17.11	17.30	17.49	17.18	17.35	17.55	17.28	17.40	17.60	17.35	17.44	17.63
125	TC	142,532	153,597	166,725	147,001	157,643	170,997	155,710	162,460	176,337	162,322	167,053	181,056
	SHC	122,183	105,764	84,937	129,963	113,853	90,345	140,464	124,686	98,239	146,429	134,205	105,435
	kW	18.32	18.50	18.69	18.38	18.55	18.74	18.49	18.59	18.79	18.56	18.63	18.82

50TJM24-50Hz													
Temp (C) Air Entering Condenser (Edb)		Evaporator Air - (L/s)/BPF											
		2360 / 0.176			2690 / 0.182			3162 / 0.214			3540 / 0.230		
		Evaporator Air - EWB (C)											
		17	19	22	17	19	22	17	19	22	17	19	22
24	TC	57.7	62.7	68.2	59.8	65.0	70.7	62.1	67.8	73.5	64.9	70.1	75.8
	SHC	45.1	39.0	32.8	48.6	41.8	34.8	52.5	45.8	37.4	56.6	49.2	39.8
	kW	10.29	10.44	10.61	10.33	10.50	10.68	10.40	10.58	10.76	10.45	10.62	10.81
29	TC	55.8	60.6	65.9	57.7	62.8	68.2	60.4	65.4	70.8	62.5	67.4	73.0
	SHC	44.7	38.4	32.0	47.9	41.2	33.9	52.5	45.2	36.6	55.8	48.6	39.0
	kW	11.72	11.89	12.08	11.78	11.95	12.14	11.85	12.03	12.22	11.90	12.07	12.26
35	TC	53.6	58.4	63.3	55.1	60.3	65.4	58.2	<b>62.6</b>	67.8	60.0	64.5	69.8
	SHC	44.1	37.8	31.2	46.7	40.5	33.1	51.1	<b>44.4</b>	35.7	54.1	47.8	38.1
	kW	13.30	13.47	13.66	13.35	13.53	13.73	13.45	<b>13.60</b>	13.80	13.49	13.64	13.84
40.6	TC	50.6	55.2	59.9	52.5	56.9	61.7	54.8	58.9	63.9	57.1	60.6	65.7
	SHC	42.3	36.3	29.7	45.4	39.0	31.5	49.0	42.8	34.1	51.7	46.0	36.5
	kW	14.68	14.87	15.07	14.74	14.92	15.12	14.83	14.99	15.19	14.95	15.02	15.22
46	TC	47.6	52.0	56.4	49.6	53.5	58.0	52.0	55.3	59.9	54.4	56.7	61.5
	SHC	40.4	35.0	28.4	43.7	37.6	30.1	46.9	41.2	32.6	49.6	44.3	35.0
	kW	16.40	16.59	16.79	16.47	16.65	16.84	16.57	16.70	16.90	16.64	16.73	16.93
48	TC	43.9	47.8	52.0	45.7	49.2	53.4	48.2	50.8	55.1	50.2	52.2	56.6
	SHC	37.7	32.7	26.4	40.6	35.1	28.1	44.1	38.5	30.5	46.0	41.4	32.6
	kW	17.11	17.30	17.49	17.18	17.35	17.55	17.28	17.40	17.60	17.35	17.44	17.63
52	TC	41.8	45.0	48.9	43.1	46.2	50.1	45.6	47.6	51.7	47.6	49.0	53.1
	SHC	35.8	31.0	24.9	38.1	33.4	26.5	41.2	36.5	28.8	42.9	39.3	30.9
	kW	18.32	18.50	18.69	18.38	18.55	18.74	18.49	18.59	18.79	18.56	18.63	18.82

**Boldface** - Standard Ratings

## LEGEND

- BF — Bypass Factor
- Edb — Entering Dry-Bulb
- Ewb — Entering Wet-Bulb
- SHC — Sensible Heat Capacity (1000 Btuh) Gross
- Ldb — Leaving Dry-Bulb
- Lwb — Leaving Wet-Bulb
- TC — Total Capacity (1000 Btuh) Gross
- kW — Compressor Motor Power Input

# Cooling Capacities (cont)

50TJM28-50Hz													
Temp (F) Air Entering Condenser (Edb)		Evaporator Air - CFM/BPF											
		5000 / 0.097			6500 / 0.120			8000 / 0.152			8500 / 0.170		
		Evaporator Air - EWB (F)											
		62	67	72	62	67	72	62	67	72	62	67	72
75	TC	239,775	261,882	285,876	259,838	282,722	307,689	268,781	291,502	317,017	275,551	297,236	323,085
	SHC	178,249	153,511	128,506	209,619	178,703	146,614	227,625	193,614	156,449	239,727	205,005	164,007
	kW	11.69	11.90	12.13	11.83	12.05	12.29	11.91	12.13	12.37	11.97	12.18	12.42
85	TC	230,023	251,614	274,742	248,968	271,137	295,158	257,905	279,276	303,745	265,919	284,402	309,317
	SHC	174,132	149,633	124,613	204,505	174,582	142,495	222,229	189,432	152,241	233,673	200,579	159,708
	kW	13.36	13.59	13.83	13.51	13.74	13.99	13.60	13.81	14.07	13.67	13.86	14.12
95	TC	219,644	239,981	262,117	237,315	258,220	281,098	246,428	<b>265,436</b>	288,849	254,561	270,295	293,899
	SHC	169,379	144,625	119,721	198,703	169,253	137,323	215,118	<b>183,681</b>	146,864	224,555	194,856	154,233
	kW	15.21	15.45	15.71	15.36	15.60	15.86	15.46	<b>15.68</b>	15.94	15.54	15.73	15.99
105	TC	205,433	224,535	245,163	222,226	241,085	262,441	232,978	247,480	269,302	239,213	251,897	273,745
	SHC	167,407	142,517	117,131	196,590	167,235	134,816	210,603	181,767	144,420	219,312	193,118	151,829
	kW	16.70	16.97	17.23	16.87	17.11	17.38	16.99	17.19	17.46	17.08	17.24	17.50
115	TC	190,476	208,250	227,409	207,266	223,144	242,988	217,698	228,749	248,941	223,451	232,726	252,871
	SHC	156,571	132,945	108,424	184,169	156,520	125,286	193,147	170,448	134,465	201,218	181,095	141,569
	kW	18.55	18.83	19.10	18.74	18.97	19.24	18.88	19.04	19.31	18.95	19.09	19.36
118.4	TC	180,596	197,568	215,796	197,485	211,548	230,441	206,310	216,983	235,956	212,656	220,557	239,604
	SHC	145,657	123,814	100,714	170,828	145,929	116,552	180,665	159,230	125,167	186,222	169,050	131,856
	kW	19.55	19.83	20.12	19.75	19.98	20.26	19.89	20.05	20.33	19.98	20.09	20.37
125	TC	172,604	188,427	205,825	189,368	201,633	219,541	198,121	206,545	224,570	204,088	209,864	227,910
	SHC	140,576	118,910	96,134	163,607	140,683	111,639	171,170	153,439	120,086	176,325	162,795	126,642
	kW	20.65	20.93	21.21	20.86	21.07	21.34	21.00	21.13	21.41	21.09	21.18	21.45

50TJM28-50Hz													
Temp (C) Air Entering Condenser (Edb)		Evaporator Air - (L/s)/BPF											
		2360 / 0.097			3068 / 0.120			3776 / 0.152			4012 / 0.170		
		Evaporator Air - EWB (C)											
		17	19	22	17	19	22	17	19	22	17	19	22
24	TC	70.3	76.8	83.8	76.2	82.9	90.2	78.8	85.4	92.9	80.8	87.1	94.7
	SHC	52.2	45.0	37.7	61.4	52.4	43.0	66.7	56.7	45.9	70.3	60.1	48.1
	kW	11.69	11.90	12.13	11.83	12.05	12.29	11.91	12.13	12.37	11.97	12.18	12.42
29	TC	67.4	73.7	80.5	73.0	79.5	86.5	75.6	81.9	89.0	77.9	83.4	90.7
	SHC	51.0	43.9	36.5	59.9	51.2	41.8	65.1	55.5	44.6	68.5	58.8	46.8
	kW	13.36	13.59	13.83	13.51	13.74	13.99	13.60	13.81	14.07	13.67	13.86	14.12
35	TC	64.4	70.3	76.8	69.6	75.7	82.4	72.2	<b>77.8</b>	84.7	74.6	79.2	86.1
	SHC	49.6	42.4	35.1	58.2	49.6	40.2	63.0	<b>53.8</b>	43.0	65.8	57.1	45.2
	kW	15.21	15.45	15.71	15.36	15.60	15.86	15.46	<b>15.68</b>	15.94	15.54	15.73	15.99
40.6	TC	60.2	65.8	71.9	65.1	70.7	76.9	68.3	72.5	78.9	70.1	73.8	80.2
	SHC	49.1	41.8	34.3	57.6	49.0	39.5	61.7	53.3	42.3	64.3	56.6	44.5
	kW	16.70	16.97	17.23	16.87	17.11	17.38	16.99	17.19	17.46	17.08	17.24	17.50
46	TC	55.8	61.0	66.6	60.7	65.4	71.2	63.8	67.0	73.0	65.5	68.2	74.1
	SHC	45.9	39.0	31.8	54.0	45.9	36.7	56.6	50.0	39.4	59.0	53.1	41.5
	kW	18.55	18.83	19.10	18.74	18.97	19.24	18.88	19.04	19.31	18.95	19.09	19.36
48	TC	52.9	57.9	63.2	57.9	62.0	67.5	60.5	63.6	69.2	62.3	64.6	70.2
	SHC	42.7	36.3	29.5	50.1	42.8	34.2	52.9	46.7	36.7	54.6	49.5	38.6
	kW	19.55	19.83	20.12	19.75	19.98	20.26	19.89	20.05	20.33	19.98	20.09	20.37
52	TC	50.6	55.2	60.3	55.5	59.1	64.3	58.1	60.5	65.8	59.8	61.5	66.8
	SHC	41.2	34.9	28.2	48.0	41.2	32.7	50.2	45.0	35.2	51.7	47.7	37.1
	kW	20.65	20.93	21.21	20.86	21.07	21.34	21.00	21.13	21.41	21.09	21.18	21.45

**Boldface** - Standard Ratings

**LEGEND**

- BF — Bypass Factor
- Edb — Entering Dry-Bulb
- Ewb — Entering Wet-Bulb
- SHC — Sensible Heat Capacity (1000 Btuh) Gross
- Ldb — Leaving Dry-Bulb
- Lwb — Leaving Wet-Bulb
- TC — Total Capacity (1000 Btuh) Gross
- kW — Compressor Motor Power Input

# Cooling Capacities (cont)

50TJM34-50Hz													
Temp (F) Air Entering Condenser (Edb)		Evaporator Air - CFM/BPF											
		7000 / 0.088			8000 / 0.137			9000 / 0.164			10000 / 0.187		
		Evaporator Air - EWB (F)											
		62	67	72	62	67	72	62	67	72	62	67	72
75	TC	296,407	322,322	350,445	304,481	330,544	359,242	314,935	340,929	370,084	321,474	346,101	375,629
	SHC	230,805	197,739	164,287	246,458	209,072	170,651	264,411	224,490	181,816	276,507	235,900	189,091
	kW	16.11	16.53	16.98	16.24	16.66	17.12	16.35	16.76	17.23	16.40	16.85	17.32
85	TC	285,582	310,357	337,372	292,640	317,884	345,404	303,352	327,758	355,683	310,505	332,333	360,669
	SHC	221,030	188,913	156,233	235,918	199,898	162,353	252,940	214,892	173,198	263,050	225,898	180,220
	kW	18.01	18.45	18.93	18.23	18.58	19.07	18.26	18.69	19.18	18.40	18.78	19.27
95	TC	273,833	297,407	323,220	280,798	304,277	330,568	291,515	<b>313,566</b>	340,216	298,925	317,874	344,723
	SHC	216,055	184,261	151,628	230,680	195,218	157,689	246,964	<b>210,090</b>	168,436	254,929	221,312	175,407
	kW	20.07	20.54	21.03	20.21	20.67	21.17	20.35	<b>20.77</b>	21.28	20.50	20.87	21.37
105	TC	258,582	280,469	304,730	265,424	286,587	311,223	276,608	295,186	320,158	282,676	298,932	324,096
	SHC	210,940	179,264	146,679	224,608	190,155	152,649	237,755	204,966	163,317	247,748	215,910	170,222
	kW	21.84	22.30	22.80	21.99	22.43	22.93	22.15	22.53	23.04	22.28	22.61	23.13
115	TC	243,144	263,382	286,134	250,524	268,787	291,857	261,131	276,856	300,135	267,541	280,108	303,533
	SHC	204,616	173,820	141,334	216,845	184,650	147,245	230,564	199,527	157,848	236,223	210,168	164,694
	kW	23.89	24.33	24.84	24.06	24.46	24.96	24.21	24.56	25.06	24.36	24.64	25.14
118.4	TC	218,932	237,019	257,412	226,252	241,717	262,434	235,779	248,950	269,846	241,493	251,866	272,813
	SHC	181,977	154,711	125,473	191,666	164,449	130,781	203,780	177,710	140,295	208,912	187,284	146,443
	kW	25.72	26.18	26.71	25.91	26.31	26.83	26.07	26.41	26.93	26.23	26.49	27.01
125	TC	203,152	218,652	237,359	209,518	222,848	241,772	218,982	229,468	248,510	224,212	231,969	251,095
	SHC	170,820	145,230	117,183	179,421	154,704	122,262	188,877	167,205	131,353	193,388	176,119	137,234
	kW	26.74	27.18	27.69	26.93	27.30	27.81	27.10	27.39	27.90	27.26	27.46	27.98

50TJM34-50Hz													
Temp (C) Air Entering Condenser (Edb)		Evaporator Air - (L/s)/BPF											
		3304 / 0.088			3776 / 0.137			4248 / 0.164			4719 / 0.187		
		Evaporator Air - EWB (C)											
		17	19	22	17	19	22	17	19	22	17	19	22
24	TC	86.9	94.5	102.7	89.2	96.9	105.3	92.3	99.9	108.5	94.2	101.4	110.1
	SHC	67.6	58.0	48.1	72.2	61.3	50.0	77.5	65.8	53.3	81.0	69.1	55.4
	kW	16.11	16.53	16.98	16.24	16.66	17.12	16.35	16.76	17.23	16.46	16.85	17.32
29	TC	83.7	91.0	98.9	85.8	93.2	101.2	88.9	96.1	104.2	91.0	97.4	105.7
	SHC	64.8	55.4	45.8	69.1	58.6	47.6	74.1	63.0	50.8	77.1	66.2	52.8
	kW	18.01	18.45	18.93	18.23	18.58	19.07	18.26	18.69	19.18	18.40	18.78	19.27
35	TC	80.3	87.2	94.7	82.3	89.2	96.9	85.4	<b>91.9</b>	99.7	87.6	93.2	101.0
	SHC	63.3	54.0	44.4	67.6	57.2	46.2	72.4	<b>61.6</b>	49.4	74.7	64.9	51.4
	kW	20.07	20.54	21.03	20.21	20.67	21.17	20.35	<b>20.77</b>	21.28	20.50	20.87	21.37
40.6	TC	75.8	82.2	89.3	77.8	84.0	91.2	81.1	86.5	93.8	82.8	87.6	95.0
	SHC	61.8	52.5	43.0	65.8	55.7	44.7	69.7	60.1	47.9	72.6	63.3	49.9
	kW	21.84	22.30	22.80	21.99	22.43	22.93	22.15	22.53	23.04	22.28	22.61	23.13
46	TC	71.3	77.2	83.9	73.4	78.8	85.5	76.5	81.1	88.0	78.4	82.1	89.0
	SHC	60.0	50.9	41.4	63.6	54.1	43.2	67.6	58.5	46.3	69.2	61.6	48.3
	kW	23.89	24.33	24.84	24.06	24.46	24.96	24.21	24.56	25.06	24.36	24.64	25.14
48	TC	64.2	69.5	75.4	66.3	70.8	76.9	69.1	73.0	79.1	70.8	73.8	80.0
	SHC	53.3	45.3	36.8	56.2	48.2	38.3	59.7	52.1	41.1	61.2	54.9	42.9
	kW	25.72	26.18	26.71	25.91	26.31	26.83	26.07	26.41	26.93	26.23	26.49	27.01
52	TC	59.5	64.1	69.6	61.4	65.3	70.9	64.2	67.3	72.8	65.7	68.0	73.6
	SHC	50.1	42.6	34.3	52.6	45.3	35.8	55.4	49.0	38.5	56.7	51.6	40.2
	kW	26.74	27.18	27.69	26.93	27.30	27.81	27.10	27.39	27.90	27.26	27.46	27.98

**Boldface** - Standard Ratings

**LEGEND**

- BF — Bypass Factor
- Edb — Entering Dry-Bulb
- Ewb — Entering Wet-Bulb
- SHC — Sensible Heat Capacity (1000 Btuh) Gross
- Ldb — Leaving Dry-Bulb
- Lwb — Leaving Wet-Bulb
- TC — Total Capacity (1000 Btuh) Gross
- kW — Compressor Motor Power Input

# Fan Performance Table

## Unit - 50TJM - 018 - 15 Tons - 50Hz (Standard Motor)

Air Flow Rate (CFM)	Available External Static Pressure (in. wg)														
	0.2			0.4			0.6			0.8			1.0		
	RPM	KWI	BHP	RPM	KWI	BHP	RPM	KWI	BHP	RPM	KWI	BHP	RPM	KWI	BHP
4000	555	0.75	0.83	622	0.91	1.01	686	1.09	1.21	<b>747</b>	<b>1.28</b>	<b>1.42</b>	<b>804</b>	<b>1.47</b>	<b>1.64</b>
4500	589	0.96	1.07	652	1.14	1.27	711	1.33	1.48	<b>767</b>	<b>1.53</b>	<b>1.70</b>	<b>823</b>	<b>1.74</b>	<b>1.93</b>
5000	624	1.21	1.34	682	1.40	1.56	737	1.61	1.79	<b>790</b>	<b>1.82</b>	<b>2.03</b>	<b>841</b>	<b>2.04</b>	<b>2.27</b>
5500	658	1.50	1.67	711	1.71	1.90	<b>762</b>	<b>1.92</b>	<b>2.14</b>	<b>813</b>	<b>2.15</b>	<b>2.39</b>	<b>861</b>	<b>2.38</b>	<b>2.65</b>
6000	689	1.83	2.03	739	2.04	2.27	<b>788</b>	<b>2.28</b>	<b>2.53</b>	<b>835</b>	<b>2.51</b>	<b>2.79</b>	<b>881</b>	<b>2.75</b>	<b>3.06</b>
6500	721	2.19	2.44	<b>765</b>	<b>2.42</b>	<b>2.69</b>	<b>811</b>	<b>2.66</b>	<b>2.95</b>	<b>855</b>	<b>2.90</b>	<b>3.23</b>	<b>899</b>	<b>3.16</b>	<b>3.51</b>
7000	<b>745</b>	<b>2.57</b>	<b>2.86</b>	<b>788</b>	<b>2.80</b>	<b>3.12</b>	<b>830</b>	<b>3.05</b>	<b>3.39</b>	<b>873</b>	<b>3.30</b>	<b>3.68</b>	<b>914</b>	<b>3.57</b>	<b>3.97</b>

## Unit - 50TJM - 018 - 15 Tons - 50Hz (Standard Motor) (cont)

Air Flow Rate (CFM)	Available External Static Pressure (in. wg)														
	1.2			1.4			1.6			1.8			2.0		
	RPM	KWI	BHP	RPM	KWI	BHP	RPM	KWI	BHP	RPM	KWI	BHP	RPM	KWI	BHP
4000	<b>859</b>	<b>1.68</b>	<b>1.87</b>	<b>910</b>	<b>1.95</b>	<b>2.17</b>	<b>959</b>	<b>2.10</b>	<b>2.34</b>	<b>1007</b>	<b>2.33</b>	<b>2.59</b>	1052	2.55	2.84
4500	<b>875</b>	<b>1.95</b>	<b>2.17</b>	<b>924</b>	<b>2.18</b>	<b>2.42</b>	<b>971</b>	<b>2.41</b>	<b>2.68</b>	<b>1018</b>	<b>2.64</b>	<b>2.94</b>	1062	2.89	3.21
5000	<b>891</b>	<b>2.27</b>	<b>2.52</b>	<b>939</b>	<b>2.51</b>	<b>2.79</b>	<b>986</b>	<b>2.75</b>	<b>3.06</b>	<b>1030</b>	<b>3.01</b>	<b>3.34</b>	1073	3.25	3.62
5500	<b>909</b>	<b>2.62</b>	<b>2.91</b>	<b>955</b>	<b>2.87</b>	<b>3.20</b>	<b>998</b>	<b>3.12</b>	<b>3.47</b>	1042	3.39	3.78	1083	3.66	4.07
6000	<b>925</b>	<b>3.01</b>	<b>3.34</b>	<b>969</b>	<b>3.27</b>	<b>3.64</b>	<b>1012</b>	<b>3.53</b>	<b>3.93</b>	1054	3.80	4.23	1094	4.09	4.55
6500	<b>942</b>	<b>3.42</b>	<b>3.80</b>	983	3.69	4.10	1024	3.96	4.41	1065	4.25	4.73	1104	4.54	5.05
7000	954	3.84	4.27	994	4.12	4.58	1034	4.40	4.90	1072	4.70	5.23	1110	5.01	5.57

**Bold, Italics** - Standard Motor and Drive Package

## Unit - 50TJM - 18 - 15 Tons - 50Hz (High Efficiency Motor)

Air Flow Rate (CFM)	Available External Static Pressure (in. wg)														
	0.2			0.4			0.6			0.8			1.0		
	RPM	KWI	BHP	RPM	KWI	BHP	RPM	KWI	BHP	RPM	KWI	BHP	RPM	KWI	BHP
4000	555	0.71	0.84	622	0.87	1.02	686	1.04	1.22	<b>747</b>	<b>1.22</b>	<b>1.43</b>	<b>804</b>	<b>1.40</b>	<b>1.65</b>
4500	589	0.92	1.08	652	1.09	1.28	711	1.27	1.50	<b>767</b>	<b>1.45</b>	<b>1.72</b>	<b>823</b>	<b>1.66</b>	<b>1.95</b>
5000	624	1.16	1.36	682	1.34	1.58	737	1.54	1.81	<b>790</b>	<b>1.73</b>	<b>2.04</b>	<b>841</b>	<b>1.95</b>	<b>2.30</b>
5500	658	1.43	1.69	711	1.63	1.92	<b>762</b>	<b>1.84</b>	<b>2.16</b>	<b>813</b>	<b>2.05</b>	<b>2.42</b>	<b>861</b>	<b>2.27</b>	<b>2.68</b>
6000	689	1.75	2.06	739	1.95	2.31	<b>788</b>	<b>2.16</b>	<b>2.55</b>	<b>835</b>	<b>2.39</b>	<b>2.82</b>	<b>881</b>	<b>2.63</b>	<b>3.10</b>
6500	721	2.10	2.47	<b>765</b>	<b>2.31</b>	<b>2.72</b>	<b>811</b>	<b>2.53</b>	<b>2.98</b>	<b>855</b>	<b>2.77</b>	<b>3.26</b>	<b>899</b>	<b>3.01</b>	<b>3.56</b>
7000	<b>745</b>	<b>2.45</b>	<b>2.89</b>	<b>788</b>	<b>2.67</b>	<b>3.15</b>	<b>830</b>	<b>2.91</b>	<b>3.43</b>	<b>873</b>	<b>3.16</b>	<b>3.72</b>	<b>914</b>	<b>3.40</b>	<b>4.01</b>

## Unit - 50TJM - 18 - 15 Tons - 50Hz (High Efficiency Motor) (cont)

Air Flow Rate (CFM)	Available External Static Pressure (in. wg)														
	1.2			1.4			1.6			1.8			2.0		
	RPM	KWI	BHP	RPM	KWI	BHP	RPM	KWI	BHP	RPM	KWI	BHP	RPM	KWI	BHP
4000	<b>859</b>	<b>1.60</b>	<b>1.88</b>	<b>910</b>	<b>1.86</b>	<b>2.19</b>	<b>959</b>	<b>2.01</b>	<b>2.37</b>	<b>1007</b>	<b>2.22</b>	<b>2.61</b>	1052	2.44	2.88
4500	<b>875</b>	<b>1.87</b>	<b>2.20</b>	<b>924</b>	<b>2.08</b>	<b>2.46</b>	<b>971</b>	<b>2.30</b>	<b>2.71</b>	<b>1018</b>	<b>2.52</b>	<b>2.97</b>	1062	2.75	3.25
5000	<b>891</b>	<b>2.16</b>	<b>2.55</b>	<b>939</b>	<b>2.39</b>	<b>2.82</b>	<b>986</b>	<b>2.63</b>	<b>3.10</b>	<b>1030</b>	<b>2.86</b>	<b>3.38</b>	1073	3.10	3.66
5500	<b>909</b>	<b>2.50</b>	<b>2.95</b>	<b>955</b>	<b>2.74</b>	<b>3.23</b>	<b>998</b>	<b>2.98</b>	<b>3.51</b>	1042	3.24	3.82	1083	3.48	4.11
6000	<b>925</b>	<b>2.86</b>	<b>3.38</b>	<b>969</b>	<b>3.11</b>	<b>3.67</b>	<b>1012</b>	<b>3.37</b>	<b>3.98</b>	1054	3.63	4.29	1094	3.90	4.60
6500	<b>942</b>	<b>3.26</b>	<b>3.85</b>	983	3.51	4.14	1024	3.78	4.46	1065	4.06	4.79	1104	4.33	5.11
7000	954	3.66	4.32	994	3.92	4.63	1034	4.20	4.95	1072	4.48	5.29	1110	4.77	5.63

**Bold, Italics** - High Efficiency Motor and Drive Package

### Legend:

RPM - Revolutions Per Minute  
 KWI - Kilo Watts Input to Motor  
 BHP - Brake Horsepower Input to Fan  
 CFM - Cubic Feet per Minute

### Notes:

- Do not adjust motor rpm such that motor maximum bhp and/or watts is exceeded at the maximum operatin cfm.
- Static Pressure (i.e Filters) must be added to external static pressure before entering fan performance table.
- Interpolation is permissible. Do not extrapolate.
- Fan performance is based on wet coils, clean filters and casing losses.
- Extensive motor and drive testing on these units ensures that the full brake horsepower and watts range of the motor can be utilized with confidence. Using your fan motors up to the watts or bhp rating shown will not result in nuisance tripping or premature motor failure. Unit warranty will not be affected.
- Bold data shows the range of air flow rate for unit management system, other rpms require field-supplied drive.
- Use of field-supplied motor may affect wiring size. Contact your Carrier representative for details.
- Conversion - Bhp to KWI

$$KWI = \frac{Bhp \times 0.746}{\text{Motor efficiency}}$$

# Fan Performance Table (cont)

## Unit - 50TJM - 24 - 19 Tons - 50Hz (Standard Motor)

Air Flow Rate (CFM)	Available External Static Pressure (in. wg)														
	0.2			0.4			0.6			0.8			1.0		
	RPM	KWI	BHP	RPM	KWI	BHP	RPM	KWI	BHP	RPM	KWI	BHP	RPM	KWI	BHP
5000	583	1.30	1.48	642	1.51	1.73	698	1.75	1.99	<b>753</b>	<b>1.99</b>	<b>2.27</b>	<b>805</b>	<b>2.25</b>	<b>2.57</b>
5500	617	1.63	1.85	672	1.86	2.12	724	2.10	2.40	<b>775</b>	<b>2.36</b>	<b>2.69</b>	<b>825</b>	<b>2.63</b>	<b>3.00</b>
6000	654	2.01	2.29	704	2.25	2.57	<b>752</b>	<b>2.51</b>	<b>2.86</b>	<b>800</b>	<b>2.78</b>	<b>3.17</b>	<b>847</b>	<b>3.07</b>	<b>3.50</b>
6500	689	2.45	2.79	735	2.71	3.09	<b>781</b>	<b>2.98</b>	<b>3.40</b>	<b>826</b>	<b>3.27</b>	<b>3.72</b>	<b>871</b>	<b>3.57</b>	<b>4.06</b>
7000	725	2.95	3.36	<b>768</b>	<b>3.22</b>	<b>3.67</b>	<b>811</b>	<b>3.51</b>	<b>4.00</b>	<b>854</b>	<b>3.81</b>	<b>4.34</b>	<b>895</b>	<b>4.13</b>	<b>4.70</b>
7500	<b>761</b>	<b>3.51</b>	<b>4.00</b>	<b>802</b>	<b>3.80</b>	<b>4.34</b>	<b>842</b>	<b>4.10</b>	<b>4.68</b>	<b>882</b>	<b>4.42</b>	<b>5.03</b>	921	4.74	5.41

## Unit - 50TJM - 24 - 19 Tons - 50Hz (Standard Motor) (cont)

Air Flow Rate (CFM)	Available External Static Pressure (in. wg)														
	1.2			1.4			1.6			1.8			2.0		
	RPM	KWI	BHP	RPM	KWI	BHP	RPM	KWI	BHP	RPM	KWI	BHP	RPM	KWI	BHP
5000	<b>856</b>	<b>2.52</b>	<b>2.87</b>	<b>906</b>	<b>2.80</b>	<b>3.19</b>	<b>954</b>	<b>3.08</b>	<b>3.51</b>	<b>998</b>	<b>3.37</b>	<b>3.84</b>	<b>1042</b>	<b>3.67</b>	<b>4.18</b>
5500	<b>874</b>	<b>2.92</b>	<b>3.32</b>	<b>920</b>	<b>3.20</b>	<b>3.65</b>	<b>966</b>	<b>3.50</b>	<b>3.99</b>	<b>1009</b>	<b>3.81</b>	<b>4.34</b>	1052	4.13	4.70
6000	<b>893</b>	<b>3.36</b>	<b>3.83</b>	<b>938</b>	<b>3.67</b>	<b>4.18</b>	<b>980</b>	<b>3.98</b>	<b>4.53</b>	<b>1023</b>	<b>4.30</b>	<b>4.90</b>	1064	4.63	5.28
6500	<b>913</b>	<b>3.87</b>	<b>4.41</b>	<b>956</b>	<b>4.19</b>	<b>4.77</b>	<b>998</b>	<b>4.51</b>	<b>5.14</b>	1038	4.85	5.53	1077	5.19	5.92
7000	<b>936</b>	<b>4.44</b>	<b>5.06</b>	976	4.77	5.43	1016	5.11	5.82	1055	5.46	6.22	1094	5.82	6.63
7500	959	5.07	5.78	998	5.42	6.17	1035	5.77	6.57	1073	6.13	6.99	1110	6.50	7.40

**Bold, Italics** - Standard Motor and Drive Package

## Unit - 50TJM - 24 - 19 Tons - 50Hz (High Efficiency Motor)

Air Flow Rate (CFM)	Available External Static Pressure (in. wg)														
	0.2			0.4			0.6			0.8			1.0		
	RPM	KWI	BHP	RPM	KWI	BHP	RPM	KWI	BHP	RPM	KWI	BHP	RPM	KWI	BHP
5000	583	1.25	1.49	642	1.46	1.74	698	1.69	2.01	<b>753</b>	<b>1.92</b>	<b>2.29</b>	<b>805</b>	<b>2.17</b>	<b>2.59</b>
5500	617	1.57	1.87	672	1.79	2.14	724	2.03	2.42	<b>775</b>	<b>2.28</b>	<b>2.71</b>	<b>825</b>	<b>2.54</b>	<b>3.03</b>
6000	654	1.94	2.31	704	2.18	2.60	<b>752</b>	<b>2.42</b>	<b>2.89</b>	<b>800</b>	<b>2.69</b>	<b>3.20</b>	<b>847</b>	<b>2.96</b>	<b>3.53</b>
6500	689	2.36	2.81	735	2.61	3.12	<b>781</b>	<b>2.87</b>	<b>3.43</b>	<b>826</b>	<b>3.15</b>	<b>3.76</b>	<b>871</b>	<b>3.44</b>	<b>4.10</b>
7000	725	2.84	3.39	<b>768</b>	<b>3.11</b>	<b>3.71</b>	<b>811</b>	<b>3.39</b>	<b>4.04</b>	<b>854</b>	<b>3.68</b>	<b>4.39</b>	<b>895</b>	<b>3.98</b>	<b>4.74</b>
7500	<b>761</b>	<b>3.39</b>	<b>4.04</b>	<b>802</b>	<b>3.67</b>	<b>4.38</b>	<b>842</b>	<b>3.96</b>	<b>4.73</b>	<b>882</b>	<b>4.26</b>	<b>5.08</b>	921	4.57	5.46

## Unit - 50TJM - 24 - 19 Tons - 50Hz (High Efficiency Motor) (cont)

Air Flow Rate (CFM)	Available External Static Pressure (in. wg)														
	1.2			1.4			1.6			1.8			2.0		
	RPM	KWI	BHP	RPM	KWI	BHP	RPM	KWI	BHP	RPM	KWI	BHP	RPM	KWI	BHP
5000	<b>856</b>	<b>2.43</b>	<b>2.90</b>	<b>906</b>	<b>2.70</b>	<b>3.22</b>	<b>954</b>	<b>2.98</b>	<b>3.55</b>	<b>998</b>	<b>3.25</b>	<b>3.88</b>	<b>1042</b>	<b>3.54</b>	<b>4.23</b>
5500	<b>874</b>	<b>2.81</b>	<b>3.36</b>	<b>920</b>	<b>3.09</b>	<b>3.68</b>	<b>966</b>	<b>3.38</b>	<b>4.03</b>	<b>1009</b>	<b>3.68</b>	<b>4.39</b>	1052	3.98	4.74
6000	<b>893</b>	<b>3.25</b>	<b>3.87</b>	<b>938</b>	<b>3.54</b>	<b>4.23</b>	<b>980</b>	<b>3.84</b>	<b>4.58</b>	<b>1023</b>	<b>4.15</b>	<b>4.95</b>	1064	4.47	5.33
6500	<b>913</b>	<b>3.73</b>	<b>4.45</b>	<b>956</b>	<b>4.04</b>	<b>4.81</b>	<b>998</b>	<b>4.36</b>	<b>5.20</b>	1038	4.68	5.58	1077	5.01	5.98
7000	<b>936</b>	<b>4.28</b>	<b>5.11</b>	976	4.60	5.49	1016	4.93	5.88	1055	5.27	6.28	1094	5.61	6.69
7500	959	4.89	5.84	998	5.22	6.23	1035	5.57	6.64	1073	5.91	7.05	1110	6.27	7.48

**Bold, Italics** - High Efficiency Motor and Drive Package

### Legend:

**RPM** - Revolutions Per Minute  
**KWI** - Kilo Watts Input to Motor  
**BHP** - Brake Horsepower Input to Fan  
**CFM** - Cubic Feet per Minute

### Notes:

- Do not adjust motor rpm such that motor maximum bhp and/or watts is exceeded at the maximum operatin cfm.
- Static Pressure (i.e Filters) must be added to external static pressure before entering fan performance table.
- Interpolation is permissible. Do not extrapolate.
- Fan performance is based on wet coils, clean filters and casing losses.
- Extensive motor and drive testing on these units ensures that the full brake horsepower and watts range of the motor can be utilized with confidence. Using your fan motors up to the watts or bhp rating shown will not result in nuisance tripping or premature motor failure. Unit warranty will not be affected.
- Bold data shows the range of air flow rate for unit management system, other rpms require field-supplied drive.
- Use of field-supplied motor may affect wiring size. Contact your Carrier representative for details.
- Conversion - Bhp to KWI

$$KWI = \frac{Bhp \times 0.746}{\text{Motor efficiency}}$$



# Fan Performance Table (cont)

## Unit - 50TJM - 28 - 23 Tons - 50Hz (Standard Motor)

Air Flow Rate (CFM)	Available External Static Pressure (in. wg)														
	0.2			0.4			0.6			0.8			1.0		
	RPM	KWI	BHP	RPM	KWI	BHP	RPM	KWI	BHP	RPM	KWI	BHP	RPM	KWI	BHP
5000	535	1.06	1.21	592	1.27	1.45	647	1.50	1.71	700	1.75	1.99	<b>751</b>	<b>2.02</b>	<b>2.30</b>
5500	564	1.30	1.48	618	1.53	1.74	669	1.77	2.01	718	2.03	2.31	<b>766</b>	<b>2.29</b>	<b>2.61</b>
6000	596	1.59	1.81	643	1.82	2.07	692	2.07	2.36	738	2.34	2.67	<b>783</b>	<b>2.63</b>	<b>2.99</b>
6500	625	1.92	2.18	671	2.16	2.46	715	2.43	2.77	759	2.70	3.08	<b>801</b>	<b>2.99</b>	<b>3.41</b>
7000	656	2.28	2.60	698	2.54	2.90	740	2.81	3.20	<b>781</b>	<b>3.10</b>	<b>3.53</b>	<b>821</b>	<b>3.40</b>	<b>3.88</b>
7500	686	2.70	3.08	726	2.98	3.39	<b>766</b>	<b>3.25</b>	<b>3.71</b>	<b>804</b>	<b>3.55</b>	<b>4.05</b>	<b>843</b>	<b>3.86</b>	<b>4.40</b>
8000	714	3.15	3.59	<b>753</b>	<b>3.43</b>	<b>3.91</b>	<b>790</b>	<b>3.74</b>	<b>4.26</b>	<b>827</b>	<b>4.04</b>	<b>4.61</b>	<b>864</b>	<b>4.37</b>	<b>4.98</b>
8500	743	3.64	4.15	<b>779</b>	<b>3.94</b>	<b>4.49</b>	815	4.25	4.85	849	4.57	5.20	884	4.89	5.57

## Unit - 50TJM - 28 - 23 Tons - 50Hz (Standard Motor) (cont)

Air Flow Rate (CFM)	Available External Static Pressure (in. wg)														
	1.2			1.4			1.6			1.8			2.0		
	RPM	KWI	BHP	RPM	KWI	BHP	RPM	KWI	BHP	RPM	KWI	BHP	RPM	KWI	BHP
5000	<b>801</b>	<b>2.31</b>	<b>2.63</b>	<b>849</b>	<b>2.60</b>	<b>2.97</b>	<b>898</b>	<b>2.93</b>	<b>3.34</b>	<b>944</b>	<b>3.27</b>	<b>3.73</b>	<b>989</b>	<b>3.64</b>	<b>4.15</b>
5500	<b>813</b>	<b>2.60</b>	<b>2.96</b>	<b>859</b>	<b>2.90</b>	<b>3.31</b>	<b>904</b>	<b>3.24</b>	<b>3.69</b>	<b>948</b>	<b>3.58</b>	<b>4.08</b>	<b>990</b>	<b>3.94</b>	<b>4.49</b>
6000	<b>827</b>	<b>2.93</b>	<b>3.34</b>	<b>870</b>	<b>3.24</b>	<b>3.69</b>	<b>913</b>	<b>3.57</b>	<b>4.07</b>	<b>955</b>	<b>3.92</b>	<b>4.46</b>	<b>996</b>	<b>4.28</b>	<b>4.88</b>
6500	<b>843</b>	<b>3.30</b>	<b>3.76</b>	<b>884</b>	<b>3.63</b>	<b>4.13</b>	<b>924</b>	<b>3.95</b>	<b>4.51</b>	<b>964</b>	<b>4.30</b>	<b>4.90</b>	<b>1002</b>	<b>4.67</b>	<b>5.32</b>
7000	<b>861</b>	<b>3.72</b>	<b>4.23</b>	<b>900</b>	<b>4.05</b>	<b>4.62</b>	<b>939</b>	<b>4.39</b>	<b>5.00</b>	976	4.74	5.41	1013	5.11	5.82
7500	<b>880</b>	<b>4.19</b>	<b>4.77</b>	<b>917</b>	<b>4.52</b>	<b>5.15</b>	954	4.87	5.55	989	5.22	5.95	1025	5.60	6.38
8000	899	4.69	5.35	935	5.04	5.74	969	5.39	6.15	1004	5.76	6.56	1038	6.15	7.00
8500	919	5.24	5.97	952	5.59	6.37	985	5.95	6.78	1017	6.33	7.21	1051	6.71	7.64

**Bold, Italics** - Standard Motor and Drive Package

## Unit - 50TJM - 28 - 23 Tons - 50Hz (High Efficiency Motor)

Air Flow Rate (CFM)	Available External Static Pressure (in. wg)														
	0.2			0.4			0.6			0.8			1.0		
	RPM	KWI	BHP	RPM	KWI	BHP	RPM	KWI	BHP	RPM	KWI	BHP	RPM	KWI	BHP
5000	535	1.02	1.22	592	1.22	1.46	647	1.44	1.72	700	1.69	2.01	<b>751</b>	<b>1.95</b>	<b>2.32</b>
5500	564	1.25	1.50	618	1.48	1.76	669	1.71	2.04	718	1.95	2.33	<b>766</b>	<b>2.21</b>	<b>2.63</b>
6000	596	1.54	1.83	643	1.75	2.09	692	2.00	2.39	738	2.26	2.70	<b>783</b>	<b>2.54</b>	<b>3.03</b>
6500	625	1.85	2.21	671	2.08	2.48	715	2.34	2.79	759	2.60	3.11	<b>801</b>	<b>2.89</b>	<b>3.44</b>
7000	656	2.20	2.63	698	2.45	2.93	740	2.72	3.24	<b>781</b>	<b>2.98</b>	<b>3.56</b>	<b>821</b>	<b>3.28</b>	<b>3.92</b>
7500	686	2.60	3.11	726	2.86	3.42	<b>766</b>	<b>3.14</b>	<b>3.75</b>	<b>804</b>	<b>3.42</b>	<b>4.09</b>	<b>843</b>	<b>3.72</b>	<b>4.44</b>
8000	714	3.04	3.62	<b>753</b>	<b>3.31</b>	<b>3.95</b>	<b>790</b>	<b>3.60</b>	<b>4.30</b>	<b>827</b>	<b>3.89</b>	<b>4.65</b>	<b>864</b>	<b>4.21</b>	<b>5.03</b>
8500	743	3.51	4.19	<b>779</b>	<b>3.80</b>	<b>4.53</b>	815	4.10	4.89	849	4.40	5.25	884	4.71	5.62

## Unit - 50TJM - 28 - 23 Tons - 50Hz (High Efficiency Motor) (cont)

Air Flow Rate (CFM)	Available External Static Pressure (in. wg)														
	1.2			1.4			1.6			1.8			2.0		
	RPM	KWI	BHP	RPM	KWI	BHP	RPM	KWI	BHP	RPM	KWI	BHP	RPM	KWI	BHP
5000	<b>801</b>	<b>2.22</b>	<b>2.65</b>	<b>849</b>	<b>2.51</b>	<b>3.00</b>	<b>898</b>	<b>2.83</b>	<b>3.37</b>	<b>944</b>	<b>3.16</b>	<b>3.76</b>	<b>989</b>	<b>3.51</b>	<b>4.19</b>
5500	<b>813</b>	<b>2.50</b>	<b>2.98</b>	<b>859</b>	<b>2.80</b>	<b>3.34</b>	<b>904</b>	<b>3.12</b>	<b>3.72</b>	<b>948</b>	<b>3.45</b>	<b>4.12</b>	<b>990</b>	<b>3.80</b>	<b>4.53</b>
6000	<b>827</b>	<b>2.83</b>	<b>3.37</b>	<b>870</b>	<b>3.12</b>	<b>3.72</b>	<b>913</b>	<b>3.44</b>	<b>4.10</b>	<b>955</b>	<b>3.77</b>	<b>4.50</b>	<b>996</b>	<b>4.13</b>	<b>4.92</b>
6500	<b>843</b>	<b>3.18</b>	<b>3.79</b>	<b>884</b>	<b>3.49</b>	<b>4.17</b>	<b>924</b>	<b>3.81</b>	<b>4.55</b>	<b>964</b>	<b>4.15</b>	<b>4.95</b>	<b>1002</b>	<b>4.50</b>	<b>5.37</b>
7000	<b>861</b>	<b>3.58</b>	<b>4.27</b>	<b>900</b>	<b>3.91</b>	<b>4.66</b>	<b>939</b>	<b>4.23</b>	<b>5.05</b>	976	4.57	5.46	1013	4.92	5.87
7500	<b>880</b>	<b>4.04</b>	<b>4.81</b>	<b>917</b>	<b>4.36</b>	<b>5.20</b>	954	4.69	5.60	989	5.04	6.01	1025	5.40	6.44
8000	899	4.52	5.39	935	4.86	5.79	969	5.20	6.20	1004	5.55	6.62	1038	5.92	7.07
8500	919	5.04	6.02	952	5.39	6.43	985	5.74	6.85	1017	6.09	7.27	1051	6.47	7.72

**Bold, Italics** - High Efficiency Motor and Drive Package

### Legend:

- RPM** - Revolutions Per Minute
- KWI** - Kilo Watts Input to Motor
- BHP** - Brake Horsepower Input to Fan
- CFM** - Cubic Feet per Minute

### Notes:

1. Do not adjust motor rpm such that motor maximum bhp and/or watts is exceeded at the maximum operatin cfm.
2. Static Pressure (i.e Filters) must be added to external static pressure before entering fan performance table.
3. Interpolation is permissible. Do not extrapolate.
4. Fan performance is based on wet coils, clean filters and casing losses.
5. Extensive motor and drive testing on these units ensures that the full brake horsepower and watts range of the motor can be utilized with confidence. Using your fan motors up to the watts or bhp rating shown will not result in nuisance tripping or premature motor failure. Unit warranty will not be affected.
6. Bold data shows the range of air flow rate for unit management system, other rpms require field-supplied drive.
7. Use of field-supplied motor may affect wiring size. Contact your Carrier representative for details.
8. Conversion - Bhp to KWI

$$KWI = \frac{Bhp \times 0.746}{\text{Motor efficiency}}$$

# Fan Performance Table (cont)

## Unit - 50TJM - 34 - 28 Tons - 50Hz (Standard Motor)

Air Flow Rate (CFM)	Available External Static Pressure (in. wg)														
	0.2			0.4			0.6			0.8			1.0		
	RPM	KWI	BHP	RPM	KWI	BHP	RPM	KWI	BHP	RPM	KWI	BHP	RPM	KWI	BHP
7000	661	2.42	2.79	704	2.69	3.10	<b>746</b>	<b>2.98</b>	<b>3.44</b>	<b>787</b>	<b>3.29</b>	<b>3.79</b>	<b>827</b>	<b>3.60</b>	<b>4.15</b>
7500	691	2.86	3.29	732	3.15	3.63	<b>773</b>	<b>3.45</b>	<b>3.98</b>	<b>811</b>	<b>3.77</b>	<b>4.34</b>	<b>849</b>	<b>4.10</b>	<b>4.72</b>
8000	723	3.36	3.87	<b>761</b>	<b>3.66</b>	<b>4.21</b>	<b>798</b>	<b>3.96</b>	<b>4.57</b>	<b>836</b>	<b>4.30</b>	<b>4.95</b>	<b>872</b>	<b>4.64</b>	<b>5.35</b>
8500	<b>754</b>	<b>3.90</b>	<b>4.50</b>	<b>791</b>	<b>4.21</b>	<b>4.86</b>	<b>826</b>	<b>4.55</b>	<b>5.25</b>	<b>860</b>	<b>4.88</b>	<b>5.62</b>	<b>896</b>	<b>5.24</b>	<b>6.04</b>
9000	<b>785</b>	<b>4.49</b>	<b>5.18</b>	<b>819</b>	<b>4.83</b>	<b>5.56</b>	<b>853</b>	<b>5.17</b>	<b>5.96</b>	<b>887</b>	<b>5.52</b>	<b>6.36</b>	<b>920</b>	<b>5.89</b>	<b>6.79</b>
9500	<b>814</b>	<b>5.13</b>	<b>5.92</b>	<b>846</b>	<b>5.48</b>	<b>6.31</b>	<b>879</b>	<b>5.83</b>	<b>6.73</b>	<b>910</b>	<b>6.19</b>	<b>7.14</b>	943	6.57	7.58
10000	<b>843</b>	<b>5.83</b>	<b>6.73</b>	<b>875</b>	<b>6.19</b>	<b>7.14</b>	905	6.56	7.56	936	6.94	8.00	966	7.32	8.44

## Unit - 50TJM - 34 - 28 Tons - 50Hz (Standard Motor) (cont)

Air Flow Rate (CFM)	Available External Static Pressure (in. wg)														
	1.2			1.4			1.6			1.8			2.0		
	RPM	KWI	BHP	RPM	KWI	BHP	RPM	KWI	BHP	RPM	KWI	BHP	RPM	KWI	BHP
7000	<b>867</b>	<b>3.94</b>	<b>4.54</b>	<b>906</b>	<b>4.28</b>	<b>4.94</b>	<b>945</b>	<b>4.65</b>	<b>5.36</b>	<b>983</b>	<b>5.02</b>	<b>5.79</b>	<b>1020</b>	<b>5.41</b>	<b>6.24</b>
7500	<b>887</b>	<b>4.44</b>	<b>5.12</b>	<b>924</b>	<b>4.79</b>	<b>5.52</b>	<b>961</b>	<b>5.15</b>	<b>5.94</b>	<b>996</b>	<b>5.54</b>	<b>6.38</b>	1032	5.93	6.84
8000	<b>908</b>	<b>4.99</b>	<b>5.75</b>	<b>944</b>	<b>5.36</b>	<b>6.17</b>	<b>978</b>	<b>5.73</b>	<b>6.60</b>	<b>1012</b>	<b>6.12</b>	<b>7.05</b>	1046	6.51	7.51
8500	<b>930</b>	<b>5.60</b>	<b>6.45</b>	<b>964</b>	<b>5.98</b>	<b>6.89</b>	<b>997</b>	<b>6.36</b>	<b>7.34</b>	1029	6.74	7.77	1062	7.15	8.25
9000	<b>952</b>	<b>6.25</b>	<b>7.21</b>	985	6.64	7.65	1017	7.03	8.11	1049	7.45	8.58	1080	7.86	9.06
9500	973	6.96	8.02	1004	7.34	8.46	1035	7.75	8.94	1065	8.16	9.41	1095	8.59	9.91
10000	996	7.72	8.90	1026	8.12	9.36	1055	8.53	9.84	1085	8.97	10.34	1114	9.40	10.84

**Bold, Italics** - Standard Motor and Drive Package

## Unit - 50TJM - 34 - 28 Tons - 50Hz (High Efficiency Motor)

Air Flow Rate (CFM)	Available External Static Pressure (in. wg)														
	0.2			0.4			0.6			0.8			1.0		
	RPM	KWI	BHP	RPM	KWI	BHP	RPM	KWI	BHP	RPM	KWI	BHP	RPM	KWI	BHP
7000	661	2.33	2.81	704	2.59	3.12	<b>746</b>	<b>2.86</b>	<b>3.46</b>	<b>787</b>	<b>3.16</b>	<b>3.82</b>	<b>827</b>	<b>3.46</b>	<b>4.18</b>
7500	691	2.75	3.31	732	3.02	3.65	<b>773</b>	<b>3.32</b>	<b>4.01</b>	<b>811</b>	<b>3.62</b>	<b>4.37</b>	<b>849</b>	<b>3.94</b>	<b>4.75</b>
8000	723	3.22	3.89	<b>761</b>	<b>3.51</b>	<b>4.24</b>	<b>798</b>	<b>3.81</b>	<b>4.60</b>	<b>836</b>	<b>4.13</b>	<b>4.98</b>	<b>872</b>	<b>4.45</b>	<b>5.37</b>
8500	<b>754</b>	<b>3.74</b>	<b>4.52</b>	<b>791</b>	<b>4.05</b>	<b>4.89</b>	<b>826</b>	<b>4.37</b>	<b>5.27</b>	<b>860</b>	<b>4.69</b>	<b>5.66</b>	<b>896</b>	<b>5.03</b>	<b>6.07</b>
9000	<b>785</b>	<b>4.32</b>	<b>5.21</b>	<b>819</b>	<b>4.64</b>	<b>5.60</b>	<b>853</b>	<b>4.97</b>	<b>5.99</b>	<b>887</b>	<b>5.30</b>	<b>6.40</b>	<b>920</b>	<b>5.65</b>	<b>6.82</b>
9500	<b>814</b>	<b>4.93</b>	<b>5.95</b>	<b>846</b>	<b>5.27</b>	<b>6.35</b>	<b>879</b>	<b>5.60</b>	<b>6.76</b>	<b>910</b>	<b>5.95</b>	<b>7.18</b>	943	6.31	7.61
10000	<b>843</b>	<b>5.60</b>	<b>6.76</b>	<b>875</b>	<b>5.95</b>	<b>7.18</b>	905	6.30	7.61	936	6.66	8.04	966	7.03	8.49

## Unit - 50TJM - 34 - 28 Tons - 50Hz (High Efficiency Motor) (cont)

Air Flow Rate (CFM)	Available External Static Pressure (in. wg)														
	1.2			1.4			1.6			1.8			2.0		
	RPM	KWI	BHP	RPM	KWI	BHP	RPM	KWI	BHP	RPM	KWI	BHP	RPM	KWI	BHP
7000	<b>867</b>	<b>3.79</b>	<b>4.57</b>	<b>906</b>	<b>4.12</b>	<b>4.97</b>	<b>945</b>	<b>4.47</b>	<b>5.39</b>	<b>983</b>	<b>4.83</b>	<b>5.82</b>	<b>1020</b>	<b>5.20</b>	<b>6.27</b>
7500	<b>887</b>	<b>4.27</b>	<b>5.15</b>	<b>924</b>	<b>4.60</b>	<b>5.55</b>	<b>961</b>	<b>4.95</b>	<b>5.98</b>	<b>996</b>	<b>5.32</b>	<b>6.42</b>	1032	5.70	6.88
8000	<b>908</b>	<b>4.80</b>	<b>5.79</b>	<b>944</b>	<b>5.15</b>	<b>6.21</b>	<b>978</b>	<b>5.51</b>	<b>6.64</b>	<b>1012</b>	<b>5.88</b>	<b>7.09</b>	1046	6.26	7.55
8500	<b>930</b>	<b>5.38</b>	<b>6.49</b>	<b>964</b>	<b>5.74</b>	<b>6.93</b>	<b>997</b>	<b>6.11</b>	<b>7.37</b>	1029	6.48	7.82	1062	6.88	8.30
9000	<b>952</b>	<b>6.01</b>	<b>7.25</b>	985	6.38	7.70	1017	6.76	8.15	1049	7.15	8.63	1080	7.56	9.12
9500	973	6.68	8.06	1004	7.06	8.51	1035	7.45	8.99	1065	7.84	9.46	1095	8.26	9.96
10000	996	7.42	8.95	1026	7.80	9.41	1055	8.21	9.90	1085	8.62	10.40	1114	9.03	10.90

**Bold, Italics** - High Efficiency Motor and Drive Package

### Legend:

**RPM** - Revolutions Per Minute  
**KWI** - Kilo Watts Input to Motor  
**BHP** - Brake Horsepower Input to Fan  
**CFM** - Cubic Feet per Minute

### Notes:

- Do not adjust motor rpm such that motor maximum bhp and/or watts is exceeded at the maximum operatin cfm.
- Static Pressure (i.e Filters) must be added to external static pressure before entering fan performance table.
- Interpolation is permissible. Do not extrapolate.
- Fan performance is based on wet coils, clean filters and casing losses.
- Extensive motor and drive testing on these units ensures that the full brake horsepower and watts range of the motor can be utilized with confidence. Using your fan motors up to the watts or bhp rating shown will not result in nuisance tripping or premature motor failure. Unit warranty will not be affected.
- Bold data shows the range of air flow rate for unit management system, other rpms require field-supplied drive.
- Use of field-supplied motor may affect wiring size. Contact your Carrier representative for details.
- Conversion - Bhp to KWI

$$KWI = \frac{Bhp \times 0.746}{\text{Motor efficiency}}$$

## Motor Efficiency Table

Unit	50TJM-18	50TJM-24	50TJM-28	50TJM-34
HP (kW)	4 (3)	5 (4)	5 (4)	7.5 (5.5)
Standard Efficiency	0.83	0.85	0.85	0.86
High Efficiency	0.88	0.89	0.89	0.90

## Fan RPM At Motor Pulley Settings

Freq.	Unit 50TJM	Motor Pulley Turns Open - (English)												
		0	1/2	1	1 1/2	2	2 1/2	3	3 1/2	4	4 1/2	5	5 1/2	6
50Hz	18	-	-	1030	1001	978	946	918	884	<b>860</b>	830	804	775	745
	24	-	-	1041	1011	989	956	928	894	<b>870</b>	839	813	784	753
	28	-	-	1041	1011	989	956	928	894	<b>870</b>	839	813	784	753
	34	1029	996	960	<b>928</b>	902	875	847	830	813	791	774	757	740

Freq.	Unit 50TJM	Motor Pulley Turns Open - (SI)												
		0	1/2	1	1 1/2	2	2 1/2	3	3 1/2	4	4 1/2	5	5 1/2	6
50Hz	18	-	-	17.2	16.7	16.3	15.8	15.3	14.7	<b>14.3</b>	13.8	13.4	12.9	12.4
	24	-	-	17.4	16.9	16.5	15.9	15.5	14.9	<b>14.5</b>	14.0	13.5	13.1	12.5
	28	-	-	17.4	16.9	16.5	15.9	15.5	14.9	<b>14.5</b>	14.0	13.5	13.1	12.5
	34	17.2	16.6	16.0	<b>15.5</b>	15.0	14.6	14.1	13.8	13.5	13.2	12.9	12.6	12.3

The standard belt size may not cover all the above range. Other RPMs require field supplied drive package.  
 Bold RPM is the factory setting .

## Sound Rating Data

Unit Sound (dB) at 50Hz (Based on cooling mode)										
Unit 50TJM	Cooling Stages	A-Weighted	63	125	250	500	1000	2000	4000	8000
18	2	90.3	96	88	88	88	85.6	82.4	77.8	71.6
24	2	90.9	96	87	90	89	85.7	82.5	78.6	72.4
28	2	90.6	90	91	88	88	86	82	79.1	72.1
34	2	91.1	91	92	89	89	86.3	82.6	79.8	72.7

dB – Decibel

### NOTES:

1. Outdoor sound data is measure in accordance with AHRI standard 370 – 2011.
2. Measurements are expressed in terms of sound power. Do not compare these values to sound pressure values because sound pressure accounts for specific environment factors which do not match individual applications. Sound power values are independent of the environment and therefore more accurate.
3. A – Weighted sound ratings filter out very high and very low frequencies, to better approximate the response of an “average” human ear. A – Weighted measurements for Carrier units are taken in accordance with 370 – 2011.

# Electrical Data Table

50TJM Size 18 - 34				Compressor				OFM			IFM Type	IFM		Electric Heater		MCA	MOCP $\diamond$
Unit Size 50TJM	Min Voltage	Max Voltage	Power Supply V / Ph / Hz	No.1		No.2		Qty	HP	FLA		HP	FLA	Appl. KW	FLA		
				RLA	LRA	RLA	LRA										
18	360	440	400 / 3 / 50	12.2	101	12.2	101	2	1	3.4	Std. Eff.	4	6.3	-	-	40.6	50
	360	440	400 / 3 / 50	12.2	101	12.2	101	2	1	3.4	High Eff.	4	6.15	-	-	40.4	50
	360	440	400 / 3 / 50	12.2	101	12.2	101	2	1	3.4	Std. Eff.	4	6.3	21	30.3	44.2	50
	360	440	400 / 3 / 50	12.2	101	12.2	101	2	1	3.4	High Eff.	4	6.15	21	30.3	44.0	50
24	360	440	400 / 3 / 50	16.7	111	16.7	111	2	1	3.4	Std. Eff.	5.5	8.3	-	-	52.7	60
	360	440	400 / 3 / 50	16.7	111	16.7	111	2	1	3.4	High Eff.	5.5	8	-	-	52.4	60
	360	440	400 / 3 / 50	16.7	111	16.7	111	2	1	3.4	Std. Eff.	5.5	8.3	28	40.4	58.8	90
	360	440	400 / 3 / 50	16.7	111	16.7	111	2	1	3.4	High Eff.	5.5	8	28	40.4	58.5	90
28	360	440	400 / 3 / 50	17.9	118	17.9	118	2	1	3	Std. Eff.	5.5	8.3	-	-	57.6	70
	360	440	400 / 3 / 50	17.9	118	17.9	118	2	1	3	High Eff.	5.5	8	-	-	57.3	70
	360	440	400 / 3 / 50	17.9	118	17.9	118	2	1	3	Std. Eff.	5.5	8.3	28	40.4	61.8	100
	360	440	400 / 3 / 50	17.9	118	17.9	118	2	1	3	High Eff.	5.5	8	28	40.4	61.5	100
34	360	440	400 / 3 / 50	21.8	140	21.8	140	2	1	3	Std. Eff.	7.5	11.3	-	-	66.4	80
	360	440	400 / 3 / 50	21.8	140	21.8	140	2	1	3	High Eff.	7.5	11	-	-	66.1	80
	360	440	400 / 3 / 50	21.8	140	21.8	140	2	1	3	Std. Eff.	7.5	11.3	28	40.4	66.4	100
	360	440	400 / 3 / 50	21.8	140	21.8	140	2	1	3	High Eff.	7.5	11	28	40.4	66.1	100

### Legend and Notes for Electrical Data Table

**FLA** - Full Load Amps

**IFM** - Indoor (Evaporator) Fan Motor

**LRA** - Locked Rotor Amps

**MCA** - Minimum Circuit Amps

**MOCP** - Maximum Overcurrent Protection

\* Application heater kW @ 400 volt (Using multiplication factor table in Electric Resistance Heater Data table on page 13)

**NEC** - National Electrical Code

**OFM** - Outdoor (Condenser) Fan Motor

**RLA** - Rated Load Amps

**HACR** - Heating, Air-Conditioning and Refrigeration

$\diamond$  Fuse or HACR Circuit Breaker

### Unbalanced 3-Phase Supply Voltage

Never operate a motor where phase imbalance in supply voltage is greater than 2%.

Use the following formula to determine the percentage of voltage imbalance

$$= 100 \times \frac{\text{Maximum Deviation From Average Voltage}}{\text{Average Voltage}}$$

Example: Supply Voltage is 400V - 3ph - 50Hz

AB = 392v	Average Voltage = $\frac{392 + 404 + 395}{3}$
BC = 404v	
AC = 395v	$= \frac{1191}{3} = 397V$

Determine maximum deviation from average voltage.

(AB) 397 - 392 = 5v

(BC) 404 - 397 = 7v

(AC) 457 - 397 = 2v

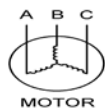

Maximum Deviation is 7v.

Determine Percentage Voltage Imbalance.

$$\% \text{ Voltage Imbalance} = 100 \times \frac{7}{397} = 1.76\%$$

This amount of phase imbalance is satisfactory as it is below the maximum allowable 2%

**IMPORTANT:** If the supply voltage phase imbalance is more than 2% contact your local electric utility company

# Electric Resistance Heater Data

UNIT 50TJM	HEATER kW		HEATER FLA (PER STAGE)		HEATER STAGES	HEAT PER STAGES	MINIMUM HEATING CFM	
	Unit Voltages		Unit Voltages				Cfm	L/s
	460		460					
18	28kW		17.3		2	50/50	4800	2265
24	37kW		23		2	50/50	6000	2832
28					2	50/50	7000	3304
34					2	50/50	7000	3304

## Accessory Heater Part Number

UNIT 50TJM	400V		
	Complete Kit P.N.	Casing P.N.	Heater Element P. N.
		( 1 Per Kit )	( 2 Per Kit )
18	50TJ600287	50TJ600289	CPHEATER036A00
24	50TJ601162		CPHEATER037A00
28	50TJ600730	50TJ600727	
34			

## Electric Heater Kits

Kit Ordering No	Description	Stages	Size (KW)
50TJ600287	Duct heater assembly, 50TJM 18 480 V	2	30
50TJ601162	Duct heater assembly, 50TJM 24 480 V	2	40
50TJ600730	Duct heater assembly, 50TJM 28 - 34 480 V	2	40

NOTE: Heaters are rated at 480 V. Use the Multiplication Factors table below to determine heater capacity for your particular voltage.

## Multiplication Factors

Heater Rating Voltage	Actual Heater Voltage		
	380	400	480
240	—	—	—
480	0.62	0.7	1

NOTE: The following equation converts kW of heat energy to Btuh: kW x 3.413 = Btuh.

EXAMPLE: 30 kW (at 480 v) heater c

= 30.0 (0.7 multiplication factor)

= 21kW

Heater capacity(kW) is based on heater voltage of 380v or 480v. If power distribution voltage to unit varies from heater voltage, heater kW will vary accordingly. To Determine heater capacity at actual unit voltage, multiply 480v capacity by multipliers found in table " Multiplication Factors" above.

MCA calculation for 50TJM 18 - 34 size units with electric heaters over 50 kW = (1.25 x IFM amps) + (1.00 x heater FLA).

# Typical wiring schematic

## WIRING:

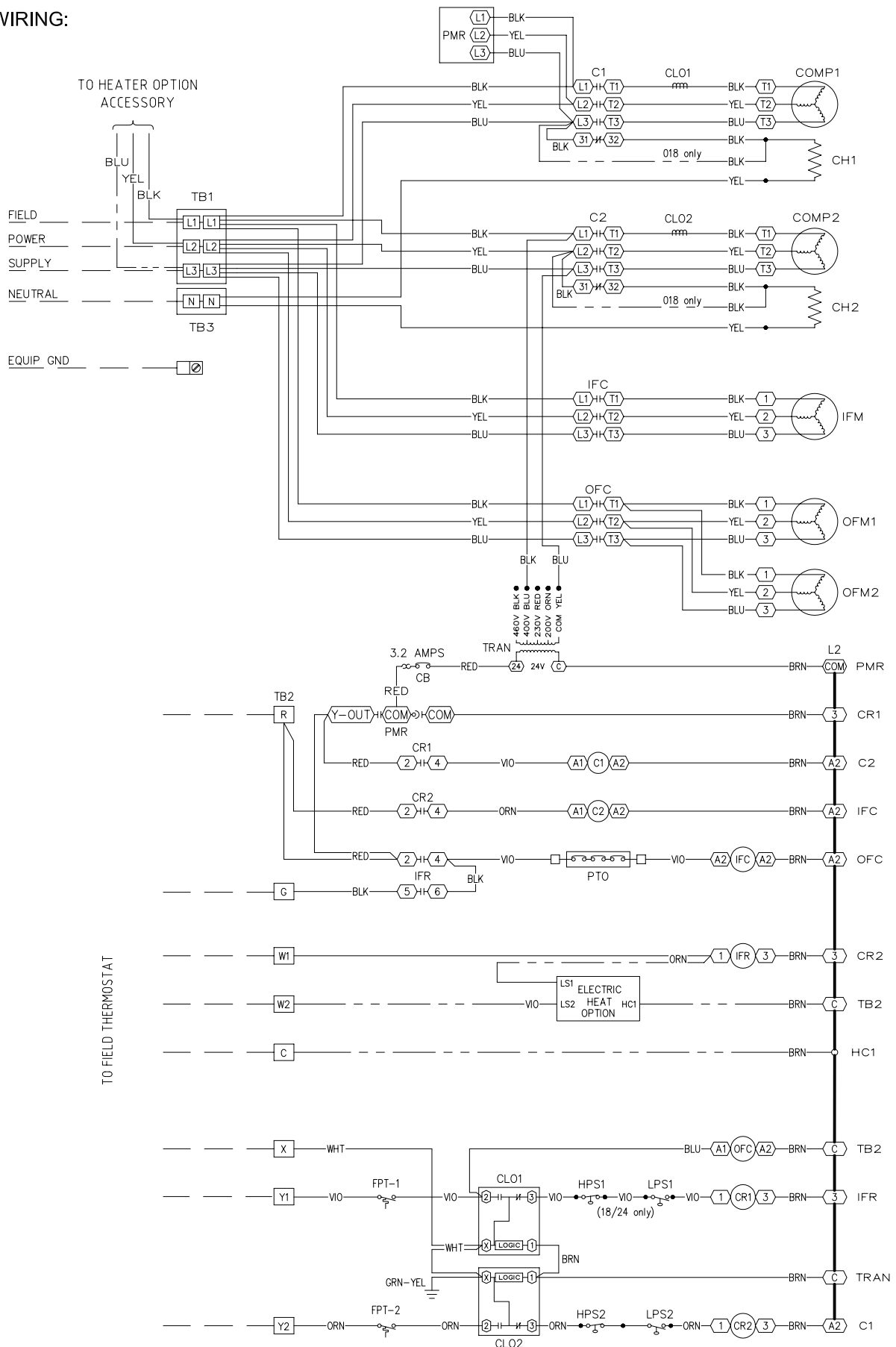

# Typical wiring schematic (Continued)

## CONTROL BOX COMPONENT ARRANGEMENT:

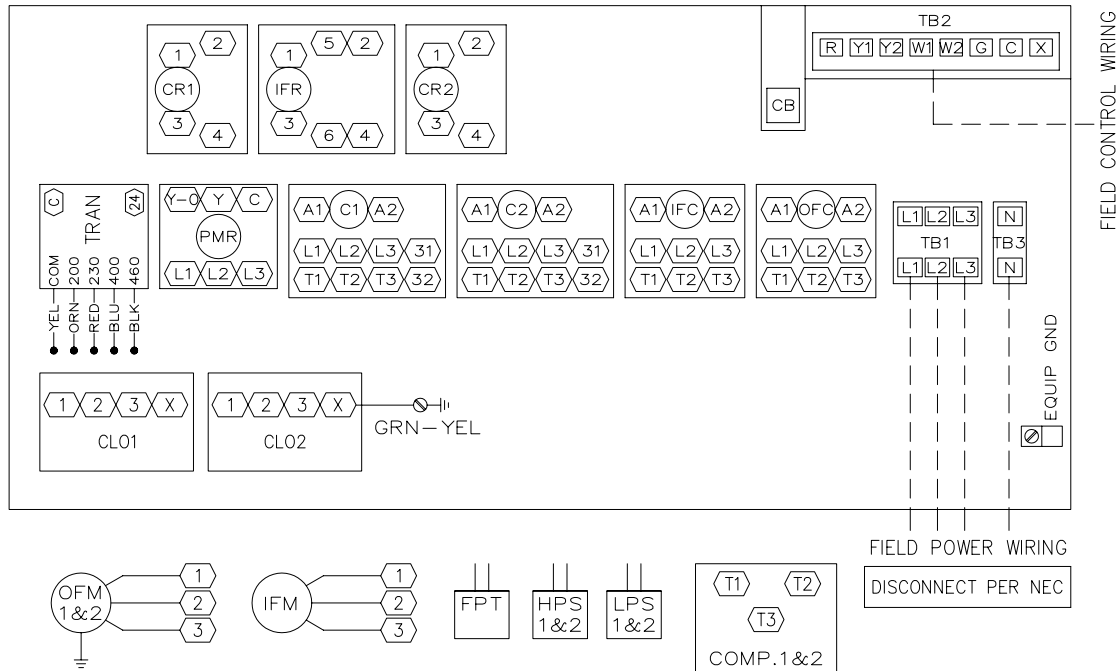

### LEGEND:

- ◻ TERMINAL (MARKED)
- TERMINAL (UNMARKED)
- ◻ TERMINAL BLOCK
- SPLICE
- FACTORY WIRING
- - - - - FIELD WIRING
- · - · - · OPTION / ACCESSORY WIRING
- TO INDICATE COMMON POTENTIAL ONLY:  
NOT TO REPRESENT WIRING

C	CONTACTOR	IFC	INDOOR FAN CONTACTOR
CB	CIRCUIT BREAKER	IFM	INDOOR FAN MOTOR
CH	CRANKCASE HEATER	IFR	INDOOR FAN RELAY
CLO	COMPRESSOR LOCKOUT	LPS	LOW PRESSURE SWITCH
COMP	COMPRESSOR MOTOR	OFC	OUTDOOR FAN CONTACTOR
CR	COMPRESSOR RELAY	OFM	OUTDOOR FAN MOTOR
FPT	FREEZE PROTECTION THERMOSTAT	PMR	PHASE MONITOR RELAY
FU	FUSE	PTO	MOTOR THERMOSTAT (NC)
GND	GROUND	TB	TERMINAL BLOCK
HC	HEATER CONTACTOR	TRAN	TRANSFORMER
HPS	HIGH PRESSURE SWITCH		

### NOTES:

- 1) IF ANY OF THE ORIGINAL WIRE FURNISHED MUST BE REPLACED, IT MUST BE REPLACED WITH TYPE 105°C WIRE OR ITS EQUIVALENT.
- 2) USE COPPER, COPPER CLAD, OR ALUMINUM CONNECTORS.
- 3) USE COPPER CONDUCTOR ONLY.
- 4) COMPRESSORS & FAN MOTORS ARE THERMALLY PROTECTED. THREE PHASE MOTORS ARE PROTECTED AGAINST PRIMARY SINGLE PHASING CONDITIONS.
- 5) THE CLO LOCKS OUT THE COMPRESSOR TO PREVENT SHORT CYCLING ON THE COMPRESSOR OVERLOAD AND SAFETY DEVICES. BEFORE REPLACING CLO, CHECK THESE DEVICES.

# Controls

## Operating Sequence

### Cooling Units

When thermostat calls for cooling, terminals G and Y1 are energized. The indoor evaporator fan contactor (IFC) and compressor contactor no. 1 (C1) are energized, and evaporator-fan motor (IFM), compressor no. 1 and condenser fan(s) start. The condenser-fan motor(s) runs continuously while unit is cooling. When the thermostat calls for a second stage of cooling by energizing Y2, compressor contactor no. 2 (C2) is energized and compressor no. 2 starts.

### Application Data

#### Thermostat

Use of 2-stage cooling thermostat with 3-5 min. time delay for compressor is recommended for all units. A 2-stage cooling thermostat is required on units if the economizer is used to provide integrated cooling.

#### Heating-To-Cooling Changeover

All units are automatic changeover from heating to cooling when automatic changeover thermostat and sub-base are used.

#### Airflow

Units are draw-thru on cooling and blow-thru on heating.

#### Maximum Airflow

To minimize the possibility of condensate blow-off from evaporator, airflow through the unit should not exceed 500 CFM/nominal ton (67.1 L/s per kW) on size 016-024 unit, and 375 CFM/nominal ton (50.3 L/s per kW) on size 018-034 unit.

#### Minimum Airflow

The minimum airflow for cooling is 300 CFM/nominal ton (40 L/s per kW) on size 016-024 unit and 280 nominal CFM/ton (38 L/s per kW) on size 018-034 unit.

#### Minimum Ambient Cooling Operation Temperature

Units are designed to operate at outdoor temperatures down to 41 F (5 C). To operate at lower outdoor-air temperatures, contact your local Carrier representative for appropriate accessories for specific applications.

#### Maximum Operating Outdoor-Air Temperature

For cooling, this temperature is 125 F (52 C) for all sizes.

#### If Accessory or Optional Heater Is Installed

Upon a call for heating through terminal W1, IFC and heater contactor no. 1 (HC1) are energized. On units equipped for 2 stages of heat, when additional heat is needed, HC2 is energized through W2.

### IMPORTANT

1. Field installed thermostat should include time delay between stages to limit the inrush current during the unit starting and to ensure proper operation of unit control.
2. The minimum heating CFM must be maintained to ensure proper operation in the Heating mode.
3. The minimum heating CFM value takes precedence over the minimum cooling CFM value.



# GUIDE SPECIFICATIONS - 50TJM SIZE 18 TO 34

## Packaged Rooftop Electric Cooling, Electric Heat, Constant Volume Application

### HVAC Guide Specifications

Carrier Model Number: **50TJM SIDE – DISCHARGE PACKAGE UNITS**

Size Range: **15 to 28 Tons, Nominal (Cooling)**

**180,000 to 288,000 Btuh, Nominal**

**20 to 30 kW (Electric Heat)**

**68,000 to 102,000 Btuh**

### Part 1 — General

#### 1.01 SYSTEM DESCRIPTION

Unit is an outdoor rooftop (or building side) mounted, electrically controlled cooling and heating (optional) unit utilizing scroll hermetic compressors for cooling duty and electric heat. Unit is specifically designed for horizontal supply and return ducts, as shown on contract drawings. Standard unit shall include a manual outdoor-air inlet.

#### 1.02 QUALITY ASSURANCE

- A. Unit meets ASHRAE 90.1 minimum efficiency requirements.
- B. Unit shall be rated in accordance with AHRI Standard 340/360 & 270.
- C. Unit shall be designed to conform to ASHRAE 15.
- D. Insulation and adhesive shall meet NFPA 90A requirements for flame spread and smoke generation.
- E. Unit casing shall be capable of withstanding 500-hour salt spray exposure per ASTM B117.
- F. Unit shall be designed and manufactured in a facility in accordance and registered by ISO 9001:2008
- G. Unit shall have a completely run test on the assembly line with copy of the run test data inside the unit.
- H. Unit shall be designed in accordance with UL Standard 1995, including tested to withstand rain.

#### 1.03 DELIVERY, STORAGE, AND HANDLING

- A. Unit shall be stored and handled per manufacturer's recommendations, positioned in upright position.
- B. Lifted by crane requires either shipping top panel or spreader bars.

### PART 2 — PRODUCTS

#### 2.01 EQUIPMENT (STANDARD)

##### A. General:

The 50TJM unit shall be a factory assembled, single piece cooling unit, with optional electric heat. Contained within the unit enclosure shall be all factory wiring, piping, controls, refrigerant charge (R-410a), and special features required prior to field start-up.

##### B. Unit Cabinet:

1. Unit cabinet shall be constructed of galvanized steel, and shall be bonderized and coated with a pre-painted baked enamel finish on all externally exposed surfaces.
2. Indoor blower compartment interior surfaces shall be insulated with a minimum 1-in thick, 1lb (.45 kg) density neoprene coated. Evaporator panels shall be double skin.
3. Base of unit shall have a minimum of four locations for factory thru-the-base electrical connections; connections shall be internal to the cabinet to protect from environmental issues.
4. Base Rail
  - a. Unit shall have base rails on a minimum of 2 sides.
  - b. Holes shall be provided in the base rails for rigging shackles to facilitate maneuvering and overhead rigging. Holes also shall be provided in the base rail for moving the rooftop by fork truck.
  - d. Base rail shall be a minimum of 12 gauge thickness.
5. Condensate pan and connections:
  - a. Shall be a sloped condensate drain pan made of a non-corrosive material.
  - b. Shall comply with ASHRAE Standard 62.
  - c. Shall use a 19mm (3/4-in.) -14 NPT drain connection at the end of the drain pan. Connection shall be made per manufacturer's recommendations.
6. Top panel shall be a multi-piece top panel linked with water tight flanges and interlocking systems.
7. Component access panels (standard) shall be easily removable for servicing.

#### C. Fans:

1. Evaporator Fan Motor:
  - a. Shall have internal automatic-reset thermal overload protection.
  - b. Shall have a maximum continuous BHP rating for continuous duty operation; no safety factors above that rating shall be required.
2. Belt-Driven Evaporator Fan:
  - a. Belt drive shall include an adjustable-pitch motor pulley.
  - b. Blower fan shall be double-inlet type with forward-curved blades.
  - c. Shall be constructed from steel with a corrosion resistant finish and dynamically balanced.
3. Condenser Fans:
  - a. Shall be a direct-driven propeller type fan.
  - b. Shall have aluminum blades riveted to corrosion-resistant steel spiders and dynamically balanced.

#### D. Compressor(s):

1. Unit shall use one fully hermetic, scroll compressor for each independent refrigeration circuit.
2. Motors shall be cooled by refrigerant gas passing through motor windings.
3. Internally protected from high discharge temperature conditions.
4. Protected from an over-temperature and over-current conditions by an internal motor overload device.
5. Compressor shall be factory mounted on rubber grommets.

#### E. Coils:

1. Standard evaporator and condenser coils shall have aluminum fins mechanically bonded to seamless internally grooved copper tubes with all joints brazed.
2. Evaporator coils shall be leak tested to 150 psig, pressure tested to 350 psig. Condenser coils shall be leak tested to 150 psig; pressure tested to 450 psig, and qualified to UL 1995 burst test at 1980 psig.
3. Optional condenser coil only shall be aluminum-fin coils with a durable epoxy-phenolic coating to provide protection in mildly corrosive coastal environments fins with copper tubes.
4. Optional condenser coil only shall be constructed of copper-fins mechanically bonded to copper tube, condenser coil available with 15 Fins per Inch (FPI) for the 50TJM-18/24 and 16 FPI for 50TJM-28/34.
5. Optional condenser and evaporator coil shall be constructed of copper-fins bonded to copper tube with evaporator copper coils available with 16 FPI and condenser coils available with 15 FPI for the 50TJM-18/24 and 16 FPI for 50TJM-28/34.
6. Copper fins provide increased corrosion resistance in moderate coastal environments where industrial air pollution is not present, copper-fin coils have extended life compared to standard or pre-coated aluminum-fin coils. All copper coils eliminate bimetallic contact to eliminate the potential for galvanic corrosion. Application in industrial environments is not recommended due to potential attack from sulfur oxide, nitrogen oxides, carbon and several other industrial airborne contaminants.

#### F. Refrigerant Circuit Components Shall Include:

1. Thermostatic expansion valve (TXV).
2. Refrigerant filter driers.

#### G. Filter Section:

1. Filters access is specified in the unit cabinet section of this specification.
2. Filters shall be held in place by a preformed filter tray, facilitating easy removal and installation.
3. Shall consist of factory-installed, low velocity, angle type (1-in.) thick washable aluminum filters.
4. Filters shall be standard, commercially available sizes.
5. Only one size filter per unit is allowed.

#### H. Controls and Safeties:

1. Unit Controls
  - a. Shall be complete with self-contained low-voltage control circuit protected by a resettable circuit breaker on the 24-v transformer side.
  - b. Shall utilize color-coded wiring.
2. Safeties:
  - a. Unit shall incorporate a solid-state compressor lockout which provides reset capability at the space thermostat, should High/Low pressure safety devices trip and shut off compressor.
  - b. Low and High-pressure switch.
  - c. Phase monitors to protect against phase loss, phase reverse and phase unbalance.
  - d. Freeze protection thermostat.
  - e. Crankcase heater is standard is for each compressor.
  - f. Automatic reset, condenser motor thermal overload protector.
  - g. Protection Thermal Overload (PTO) motor thermostat is standard for Indoor Fan Motor (IFM) protection.

I. Operating Characteristics:

1. Unit shall be capable of starting and running at 125°F (52°C) ambient outdoor temperature per maximum load criteria of AHRI Standard 360.
2. Unit with standard controls will operate in cooling down to outdoor ambient temperature of 40°F (4.4°C).

J. Electrical Requirements:

1. Electrical Connections all unit power wiring shall enter unit cabinet at a single location.

K. Motors:

1. Evaporator Fan:

- a. Shall be a totally enclosed motor.
- b. Shall use permanently lubricated bearings.
- c. Shall have a TEFC motor with thermal overload protection with an automatic reset feature.
- d. Optional High Efficiency Motor.

2. Condenser Fans:

- a. Shall be a direct-driven propeller type fan.
- b. Shall have aluminum blades riveted to corrosion-resistant steel spiders and dynamically balanced.

**Field Installed Options**

1. Electric Heater Package: The electric heater package is factory supplied for field installed. Heater assemblies are provided with internal fusing for protection of heater circuits not exceeding 25 amps each. All power wiring leads are 10 AWG and control wiring are 18AWG, both rated at 105°C. Auto reset thermo limit controls, magnetic heater contractors (24v coil) and terminal block are mounted in electric heater control box attached to heater assembly.
2. UVC Ready: The unit shall be UVC ready for easy installation. UVC Lamp is field supplied and field installed.

